

This is Exhibit "D" referred to in the Affidavit of  
Joseph Siefried sworn October 9, 2015

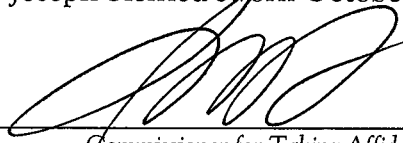

---

*Commissioner for Taking Affidavits*

# HARRIS, SHEAFFER LLP

BARRISTERS & SOLICITORS

YONGE CORPORATE CENTRE  
4100 YONGE STREET, SUITE 610, TORONTO, ONTARIO M2P 2B5  
TELEPHONE (416) 250-3300 / FACSIMILE (416) 250-3300

From: Karen McNeill  
Date: October 6, 2014

No. of Pages: 2

File No.: 090328

Please deliver the following page(s) to:

	NAME	COMPANY	FACSIMILE NO.
1.	Jonathan Mueller	144 Park Ltd.	905-944-0916
2.		Les U. Protopapas	1-519-772-1051

### COMMENTS:

144 Park Ltd. sale to Joseph Siefried and Susan Anne Siefried, Unit 4, Level 18 - Our client has advised us that the Occupancy Closing Date is October 8, 2014. We are attaching hereto a revised Interim Statement of Adjustments for your attention. We would request that the balance of documentation previously provided to you be amended to correspond to the attached Interim Statement of Adjustments.

*If you have provided our office with the closing package and funds, we will re-adjust on Final Closing for any shortfall or overpayment of the Pro-Rated Occupancy Fee.*

All other terms and conditions set out in the Agreement of Purchase and Sale shall remain the same and time to continue to remain of the essence.

*TCT - Joe  
supposed to see it  
removed @ 3:46 pm  
- note to me before  
email*

*Oct 6/14*

- BARRY ROTENBERG
- GARY H. HARRON
- ROBERT D. SHEAFFER
- PHILIP J. DRAPER
- MARK F. FRYEDMAN (1981 - 2004)
- JEFFREY P. SILVER
- STEPHEN M. KARR
- MARTIN P. HYLAKA
- MARK L. KAPLAN
- MIKHAIL J. BALS
- ARI M. KATZ
- RAGHAV NIKHAI
- ROBERT SIKORSKI

**INTERIM STATEMENT OF ADJUSTMENTS**

RE: 144 Park Ltd. sale to Joseph Siefried and Susan Anne Siefried  
 Unit 4, Level 18, Unit 28, Level A, Unit 29, Level A, Unit 67, Level A, WSCP TBR  
 Suite PH4, 144 Park Street, Waterloo, Ontario N2L 0B6

Tarion Builder Registration Number: 39278  
 Tarion Unit Enrolment Number: H1816783

Closing Date: October 2, 2014

PURCHASE PRICE inclusive of HST (where applicable)		\$ 425,890.00
UPGRADE CHARGES inclusive of HST		\$ 15,805.31
TOTAL DEPOSITS	\$ 59,948.50	
UPGRADE CHARGES PAID TO VENDOR	\$ 7,902.66	
UNADJUSTED BALANCE DUE ON THE UNIT TRANSFER DATE	\$ 365,941.50	
BALANCE DUE ON CLOSING paid by certified cheque to <i>Harris, Sheaffer LLP, In Trust</i> E. & O.E.	\$ 7,902.65	
	<u>\$441,695.31</u>	<u>\$441,695.31</u>

NOTE: In addition to the unadjusted balance due on closing, if any, the Purchaser must deliver the following cheques:

- (i) Certified Cheque payable to Harris, Sheaffer LLP in the sum of \$1,654.35 being the pro-rated amount of monthly Occupancy Fee from October 2, 2014 to the day prior to the first day of the following month.
- (ii) 4 post-dated cheques each dated the 1st of the month, in the sum of \$1,709.50 commencing November 1, 2014 payable to 144 Park Ltd.

In accordance with the Condominium Act, 1998 and the Agreement of Purchase and Sale, the Occupancy Fee comprises the following:

Estimated Total Common Expenses:	\$551.95
Estimated Realty Taxes:	\$200.00
Interest on the Unadjusted Balance Due on the Unit Transfer Date at the prescribed rate of 3.1400%	\$957.55
<b>TOTAL</b>	<u>\$1,709.50</u>

NOTE 1: All calculations with respect to Goods and Services Tax or the Harmonized Sales Tax (if applicable), will be addressed on the Final Statement of Adjustments.  
E. & O. E.

NOTE 2:

Please note it is the policy of this firm that funds being delivered to us by certified cheque for a closing must be from the purchaser's solicitor's trust account and not directly from a purchaser or any other person. No bank drafts are permitted.

This is Exhibit "E" referred to in the Affidavit of  
Joseph Siefried sworn October 9, 2015

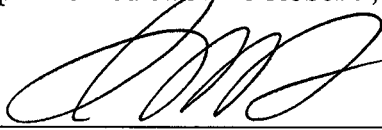

---

*Commissioner for Taking Affidavits*



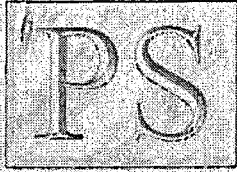

**PROTOPAPAS & SPIEGELBERG**  
BARRISTERS • SOLICITORS • NOTARIES

October 9, 2014

By e-mail to [kmcneill@harris-sheaffer.com](mailto:kmcneill@harris-sheaffer.com)  
And by Purolator Courier

Karen McNeill  
Harris, Sheaffer LLP  
610 - 4100 Yonge Street  
Toronto, ON  
M2P 2B5

Dear Ms. McNeill:

**Re: 144 Park Ltd., sale to Joseph Siefried and Susan Anne Siefried  
Unit 4, Level 18, Unit 28, Level A, Unit 29, Level A,  
Unit 67, Level A, WSCP TBR  
Suite PH4, 144 Park Street, Waterloo ON N2L 0B6**

Please find enclosed the following:

1. Direction re Title, in duplicate.
2. Occupancy Acknowledgement, in duplicate.
3. Clear Execution Certificate.
4. Our certified trust cheque in the amount of \$7,902.65, payable to Harris, Sheaffer LLP, in Trust, which represents the balance due on closing.
5. Our certified trust cheque in the amount of \$1,323.48 payable to Harris, Sheaffer for the pro-rated amount of monthly Occupancy Fee from October 8, 2014 to the day prior to the first day of the following month.
6. Four (4) post dated cheques dated November 1, 2014, December 1, 2014, January 1, 2015 and February 1, 2015 each in the amount of \$1,709.50.

We hereby undertake to forward his original letter and enclosures to your office by overnight courier.

Please advise when you have authorized the release of the keys, so that we can inform our clients accordingly.

Yours truly,  
**Protopapas & Spiegelberg**

Les U. Protopapas  
LUP/js  
Encls.

This is Exhibit "F" referred to in the Affidavit of  
Joseph Siefried sworn October 9, 2015

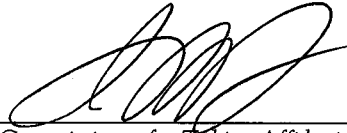

---

Commissioner for Taking Affidavits

Form 4

Condominium Act, 1998

EVIDENCE OF COMPLIANCE  
(subsection 81(6) of the Condominium Act, 1998)

To: Joseph Siefried and Susan Anne Siefried c/o Les U. Protopapas, Protopapas & Spiegelberg, Barristers and Solicitors, 22  
Frederick Street Suite 1016 Kitchener, Ontario N2H 6M6

We certify that:

1. We are a trustee of a prescribed class. [Escrow Agents for deposits with respect to a project who have entered into a Deposit Trust Agreement with the Declarant and either the Warranty Corporation or an insurer to govern money to be held in trust under Section 81 of the Act with respect to the project.]

2. On October 8, 2014, we received the amount \$7,902.65 (known as "the money") that you paid under subsection 81(1) of the *Condominium Act, 1998* in respect of the purchase or a right to the purchase of:

a proposed unit described as

Unit 4, Level 18, Unit 28, Level A, Unit 29, Level A, Unit 67, Level A, WSCP TBR, Regional Municipality of Waterloo, Regional Municipality of Waterloo  
Suite PH4, 144 Park Street, Waterloo, Ontario N2L 0B6  
144 Park Ltd.

3. We are holding the money in trust in the following trust account in Ontario:

Account No: 8421 - 090220-501  
Bank: Laurentian Bank of Canada  
Address: 130 Adelaide Street West, Suite # 200  
Toronto, Ontario  
M5H 3P5  
416-865-5732

4. You will receive notice if there is any change of trustee holding the money in trust before that person no longer has any obligations, under the *Condominium Act, 1998* or the regulations made under it, relating to the money or any security of a prescribed class that the declarant may provide for the money.

Dated this 10th day of October, 2014.

Harris, Sheaffer LLP

Mark Karoly\*

(signature)

Mark Karoly

(print name)

4100 Yonge Street Suite 610, Toronto, Ontario M2P 2B5  
Phone No.: 416 250 5800 / Fax No.: 416 250 5300

\* Executed pursuant to the Electronic Commerce Act (Ontario)

This is Exhibit "G" referred to in the Affidavit of  
Joseph Siefried sworn October 9, 2015

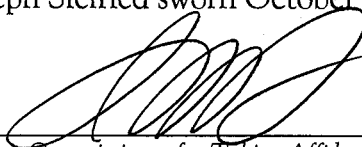

---

*Commissioner for Taking Affidavits*



# HARRIS, SHEAFFER LLP

## BARRISTERS & SOLICITORS

YONGE CORPORATE CENTRE  
4100 YONGE STREET, SUITE 610, TORONTO, ONTARIO M2P 2B5  
TELEPHONE (416) 250-3800 / FACSIMILE (416) 250-5300

June 16, 2015  
File No.: 090328  
Contact: Karen McNeill at 416-250-3695

Delivered by Facsimile Only (1-512-772-1051)

Les U. Protopapas  
Protopapas & Spiegelberg  
Barristers and Solicitors  
22 Frederick Street  
Suite 1016  
Kitchener, Ontario N2H 6M6

Dear Sirs:

RE: 144 Park Ltd. by its Court Appointed Trustee, Collins Barrow Toronto Limited sale to Joseph Siefried and Susan Anne Siefried  
Unit 4, Level 18, WSCP 591  
Suite PH4, 144 Park Street, Waterloo, Ontario N2L 0B6

We are pleased to advise that the Declaration and Description creating the condominium were registered in the Land Registry Office for the Land Titles Division of Waterloo on May 25, 2015 pursuant to Instrument Number WR882241 thereby creating Waterloo Condominium No. 591.

We also wish to advise you that Collins Barrow Toronto Limited was appointed by court order as Trustee of the property owned by 144 Park Ltd., including the units in the condominium. The court order was registered on title to said property on January 23, 2015 as Instrument No. WR863820.

At the time of execution of the Agreement of Purchase and Sale, the Vendor agreed to sell to the Purchaser(s) a second Parking Unit. Unfortunately there are not sufficient parking units available to be sold in this project. Accordingly, the Court Appointed Trustee is requesting that the Purchaser(s) agree to amend the Agreement of Purchase and Sale to delete the second Parking Unit and correspondingly reduce the Purchase Price by the amount of \$33,900.00 (inclusive of HST). If your client is agreeable to same, please sign and return a copy of this letter to us by no later than 5:00 p.m. on June 22, 2015 and we will then be in a position to set a final closing date. If we do not hear from you by that time or if your client is not agreeable to the Amendment, the Trustee may seek a Court Order terminating the Agreement of Purchase and Sale.

Yours very truly,  
Harris, Sheaffer LLP

Mark Karoly\*

Mark Karoly

\*Executed pursuant to the Electronic Commerce Act

The undersigned agrees to amend the Agreement of Purchase and Sale in the manner described above. Dated this \_\_\_\_\_ day of June, 2015.

Joseph Siefried and Susan Anne Siefried, by his/hcr/their solicitor  
Les U. Protopapas.

Per \_\_\_\_\_  
Les U. Protopapas

■  
BARRY RUTENBERG

■  
GARY H. HARALS

■  
ROBERT D. SHEAFFER

■  
PHILIP J. DRAITER

■  
MARK F. FREEDMAN  
(1981 - 2009)

■  
JEFFREY R. SILVER

■  
STEPHEN M. KARR

■  
MARTIN P. HOUSEN

■  
MARK L. KYNOLY

■  
MICHAEL J. BAUM

■  
ARI M. KATZ

■  
RAZVAN NICOLAE

■  
ROBERT SLONIG



This is Exhibit "H" referred to in the Affidavit of  
Joseph Siefried sworn October 9, 2015



---

*Commissioner for Taking Affidavits*



**PROTOPAPAS & SPIEGELBERG**  
BARRISTERS • SOLICITORS • NOTARIES

June 16, 2015

By Fax to 1-416-250-5300

Mark Karoly  
**Harris, Sheaffer LLP**  
Barristers & Solicitors  
4100 Yonge Street  
Suite 610  
Toronto, ON  
M2P 2B5

Dear Mr. Karoly:

**Re: Siefried purchase from 144 Park Ltd. By its Court  
Appointed Trustee, Collins Barrow Toronto Limited  
Suite PH4, 144 Park Street, Waterloo, Ontario**

Thank you for your letter dated June 16, 2015. My clients have been advised of the contents of the letter and the request to delete the second parking unit from the Agreement of Purchase and Sale.

Further to our telephone conversation, I confirm that my instructions are my clients are insisting on completing the purchase and sale transaction in accordance with the Agreement of Purchase and Sale that was dated October 9<sup>th</sup>, 2010 and amended on February 7<sup>th</sup>, 2011 which include two parking units. My clients entered into this transaction on the basis that they required two parking units. Interim occupancy took place in October of 2014. The interim occupancy documentation clearly included, in addition to the residential unit and storage unit, two parking spots, being Units 28 and 29 on Level A.

My clients sold their residential home to move into the condominium residence in April of 2015. In order to accommodate the limited size of the parking spaces, my clients incurred additional expenses by having to sell one of their oversized work vehicles for a smaller vehicle. They have been using and occupying the two parking spots designated to them since occupying their residence.

My clients would never have entered into the Agreement, as amended to include two parking spaces, if they did not have the opportunity to purchase two parking spaces.

Therefore, they insist on the completion of the transaction in accordance with the terms of the Agreement of Purchase and Sale, as amended, which includes two parking spaces.

I note by the Court Order of Mr. Justice Penny, dated January 22, 2015, which was registered on January 23, 2015, paragraph 3(k) authorizes the Trustee to complete the existing agreements of purchase and sale for the 129 pre-sold condominium units and related lockers and parking spaces and in subparagraph 3(l) authorizes the Trustee to apply for a vesting order to convey title to the "Sold Units". There is no provision in the Order for any power or right vested in the Trustee to amend the Agreements of Purchase and Sale without the consent of the purchaser.

I also note that the said Court Order, in paragraph 12, does not allow any provision to alter, repudiate or terminate any contract or agreement in favour of or held by the Applicant, without the written consent of the Trustee or leave of the Court. This provision implies that my clients have no unilateral right to amend or repudiate the Agreement they entered into.

To summarize, my clients intend to rely on the strict terms of the Agreement, which includes two parking spaces being sold to them and demand that the Trustee abide by their Agreement of Purchase and Sale, as amended.

Yours truly,

**Protopapas & Spiegelberg**

Per: Les U. Protopapas

LUP/cr

This is Exhibit "I" referred to in the Affidavit of  
Joseph Siefried sworn October 9, 2015

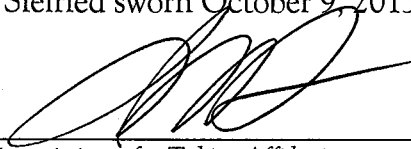
A handwritten signature in black ink, consisting of several overlapping loops and a long horizontal stroke extending to the right.

---

*Commissioner for Taking Affidavits*



# HARRIS, SHEAFFER LLP

BARRISTERS & SOLICITORS

YONGE CORPORATE CENTRE  
4100 YONGE STREET, SUITE 610, TORONTO, ONTARIO M2P 2B5  
TELEPHONE (416) 250-5800 / FACSIMILE (416) 250-5300

July 6, 2015  
File No.: 090328  
Contact: Karen McNeill at 416-250-3695

**Delivered by Facsimile Only (1-519-772-1051)**

Les U. Protopapas  
Protopapas & Spiegelberg  
Barristers and Solicitors  
22 Frederick Street  
Suite 1016  
Kitchener, Ontario N2H 6M6

Dear Sirs:

RE: 144 Park Ltd. by its Court Appointed Trustee, Collins Barrow Toronto Limited sale to Joseph Siefried and Susan Anne Siefried  
Unit 4, Level 18, WSCP 591  
Suite PH4, 144 Park Street, Waterloo, Ontario N2L 0B6

This is further to our letter to you dated June 15, 2015 relating to the parking units in the above property.

It has come to our attention that the purpose of the letter may have been misunderstood by some Purchasers so we are writing to you to clarify the reason that our urgent letter was sent.

The Condominium contains 148 residential units and 149 permanent parking units. When the Trustee assumed control of the project, it determined that there were 129 Agreements of Purchase and Sale in place with commitments to sell 156 parking units. In other words, there are insufficient parking units constructed to allow all existing Agreements to be completed in accordance with their terms. Furthermore, there are 19 unsold units in the building. As you know, a Trustee has a fiduciary duty to maximize the value of the property for the benefit of Lien Claimants and Creditors. To do so, the Trustee is of the opinion that it needs to be able to allocate some parking units to the unsold units in order to preserve marketability and sell the units at a reasonable value.

For your information, there are also ten (10) parking spaces in the building that can be used as parking until the adjoining building is constructed. At that time, these ten (10) parking spaces will become drive aisles and will be unavailable for parking purposes. The Trustee has not yet determined how these parking spaces can be allocated but it will be in a position to lease these spaces on a temporary basis.

We hope that the above provides some clarification to you as to the purpose of our prior correspondence. Based on the above, we would ask that you kindly speak with your clients and ask them whether they are prepared to reconsider their position on this matter. If they are prepared to do so, please return an executed copy of our June 15, 2015 letter by no later than July 10, 2015.

Yours very truly,  
Harris, Sheaffer LLP

Ari Katz\*

Ari Katz

\*Executed pursuant to the Electronic Commerce Act

■  
BARRY RUTENBERG

■  
GARY H. HARRIS

■  
ROBERT D. SHEAFFER

■  
PHILIP J. DRAPER

■  
MARK F. FRIEDMAN  
(1981 - 2009)

■  
JEFFREY P. SILVER

■  
SHERILY M. KARR

■  
MAKIN B. HUNTER

■  
MARK L. KARDLY

■  
MARGARET J. BALM

■  
ARI M. KATZ

■  
REYVAN NIKITAE

■  
ROBERT SILVER

This is Exhibit "J" referred to in the Affidavit of  
Joseph Siefried sworn October 9, 2015

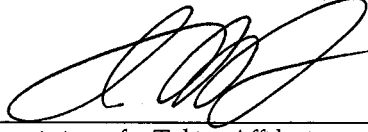

---

*Commissioner for Taking Affidavits*



# HARRIS, SHEAFFER LLP

BARRISTERS & SOLICITORS

YONGE CORPORATE CENTRE  
4100 YONGE STREET, SUITE 610, TORONTO, ONTARIO M2P 2B5  
TELEPHONE (416) 250-5800 / FACSIMILE (416) 250-5300

July 21, 2015

## FAX COVER SHEET:

**To:**  
Les U. Protopapas  
Protopapas & Spiegelberg  
Barristers and Solicitors  
Fax: 1-519-772-1051

**From:**  
Karen McNeill  
Direct Line: 416-250-3695

Number of pages including cover sheet: 1

**RE:** 144 Park Ltd. s/t Joseph Siefried and Susan Anne Siefried  
Unit 4, Level 18, Unit 28, Level A, Unit 30, Level 1, Unit 67, Level A, WSCP 591  
Occupancy Date: October 8, 2014  
Our File No: 090328

Please be advised that Collins Barrow Toronto Limited was appointed by court order as trustee (the "Trustee") of the property owned by 144 Park Ltd., including the units in the condominium. The court order was registered on title to the property on January 23, 2015 as Instrument No. WR863820.

The Trustee has been working with lenders and other stakeholders in this project, including certain members of the Ad Hoc Purchasers' Committee and the potential developer of 155 Uptown Waterloo, to find a meaningful parking solution to the current shortage of parking in 144 Park. In connection therewith, the Trustee has reached a potential solution that balances the many stakeholder interests. The allocation of some of the Parking Units in this project are now being reallocated in order to achieve this solution.

In this regard, your client has now been allocated a new Parking Unit and this allocation will take effect at noon on July 24, 2015. Your client's new Parking Unit allocation is Unit 30, Level 1. **Please advise your client that arrangements must be made to move vehicles from the previously allocated Parking Unit at noon on July 24, 2015 because the previously allocated Parking Unit has been reallocated for someone else's use commencing at noon on July 24, 2015.** Please be further advised that if your client agreed to purchase more than one Parking Unit, you must check the re line of this fax to verify which Parking Unit has been reallocated.

In the event your client requires any assistance in locating their new Parking Unit, kindly speak to the Trustee's site representative, Ms. Karla Roelofsz. The Trustee is most grateful for your cooperation and assistance in effecting this allocation. The Trustee intends to schedule a Title Transfer Date as soon as possible.

**Warning: The information contained in this fax is confidential, and may be subject to solicitor-client privilege. It is intended solely for the use of the party to whom it is addressed. Any distribution, copying or disclosure of this fax, other than by its intended recipient, is strictly prohibited. If you received this fax in error, please advise us immediately by telephone, and return the original transmission to us by mail without making a copy.**

■  
BARRY ROTENBERG

■  
GARY H. HARRIS

■  
ROBERT D. SHEAFFER

■  
PHILIP J. DRAPER

■  
MARK F. FREEDMAN  
(1981 - 2009)

■  
JEFFREY P. SILVER

■  
STEPHEN M. KARR

■  
MARTIN P. HOUSER

■  
MARK L. KAROLY

■  
MICHAEL J. BAUM

■  
ARI M. KATZ

■  
RAZVAN NICOLAE

■  
ROBERT SHORE

**Warning:** The information contained in this fax is confidential, and may be subject to solicitor-client privilege. It is intended solely for the use of the party to whom it is addressed. Any distribution, copying or disclosure of this fax, other than by its intended recipient, is strictly prohibited. If you received this fax in error, please advise us immediately by telephone, and return the original transmission to us by mail without making a copy.

This is Exhibit "K" referred to in the Affidavit of  
Joseph Siefried sworn October 9, 2015

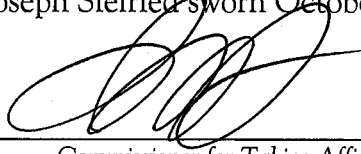

---

*Commissioner for Taking Affidavits*



**PROTOPAPAS & SPIEGELBERG**  
BARRISTERS • SOLICITORS • NOTARIES

July 23, 2015

By Fax to 1-416-250-5300

Karen McNeill  
**Harris, Sheaffer LLP**  
4100 Yonge Street  
Suite 610  
Toronto, ON  
M2P 2B5

Dear Ms. McNeill:

**Re: Siefried purchase from 144 Park Ltd. By its Court  
Appointed Trustee, Collins Barrow Toronto Limited  
Suite PH4, 144 Park Street, Waterloo, Ontario**

Thank you for your letter dated July 21, 2015.

My clients were advised of the new parking space you are allocating to them. They checked out the proposed new parking unit and quite frankly, they are baffled by what is being proposed, do not understand what this accomplishes and they are not prepared to accept the new allocated parking unit.

The proposed new parking unit appears to be the same size as what they currently use and both are indoors, so there is no reason they cannot keep the two units they currently have and have had since October of 2014. The two units they currently have provide some comfort and security for their vehicles in that the two units number 28 and 29 are obviously beside each other, but on either side of their two adjoining units there are pillars which protect their vehicles from damage being caused by other vehicles. Therefore, if there is any damage, short of vandalism, it could only be caused by themselves. The splitting up of their parking units, aside from being an inconvenience, also exposes their vehicles to potential damage, other than from their own wrongdoing.

If you are trying to give my client the new Unit 30, Level 1 space, then obviously this unit is available and it would make more sense to give it to whoever you were proposing to give our clients' current Unit 29. What is the difference for the new homeowner if he gets Unit 30, Level 1 instead of my clients' unit, thus allowing my clients to retain their two adjoining parking spaces.

Your proposal in your letter makes absolutely no sense and my clients are questioning whether there is a hidden agenda in what you are proposing. They are very frustrated with the whole situation and they insist that what they contracted for and what they have been allocated as parking spots since October of 2014 be maintained.

Yours truly,  
**Protopapas & Spiegelberg**

  
Per: Les U. Protopapas

LUP/cr

This is Exhibit "L" referred to in the Affidavit of  
Joseph Siefried sworn October 9, 2015

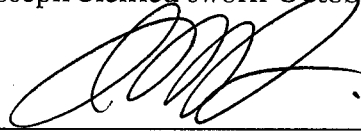

---

*Commissioner for Taking Affidavits*



## Les Protopapas

---

**From:** Les Protopapas  
**Sent:** July-24-15 12:57 PM  
**To:** 'miantorno@harris-sheaffer.com'  
**Subject:** FW: PH4 - 144 Park

Michelle, please see the email I sent to Karen McNeill minutes ago.  
Thanks – Les Protopapas

---

**From:** Les Protopapas  
**Sent:** July-24-15 12:51 PM  
**To:** 'Karen McNeill'  
**Cc:** Joe Slefried  
**Subject:** RE: PH4 - 144 Park

Dear Sir/Madam,

I have reviewed the matter with my clients and they are not pleased at all with the arbitrary manner in which they have been dealt with.

They have a legally binding contract to purchase 2 parking units. The Agreement of purchase and sale provides for the Vendor to allocate the parking space in its sole discretion. Interim Occupancy took place October 8, 2014 and at that time my clients were allocated their parking spaces and have used same continuously since then.

Your client is now attempting to reallocate their parking spaces, spaces that have already been allocated and used since last October. The agreement does not provide for the reallocation of parking spaces. My clients have also advised me that the proposed new space you are requesting they move one of their units to is for parking spaces to be leased. They are very concerned that your client is also trying to do an end around and not sell them 2 parking spaces that they have contracted to purchase.

Even if they agree to your request, which they are not accepting, is it a unit that can even be sold and is there a PIN number for the proposed new parking space?

You have also failed to provide any explanation for the request for the reallocation of the parking space – is there any legitimate reason?

Section 41 of the Agreement of purchase and sale provides for certain changes for legitimate reasons. Although we are not convinced that this requested change is even covered by this section we have not been provided with any legitimate reason for this request.

On a final note it appears that the parking issue is holding up the transfer of the residential unit, parking spaces and storage space to my clients and in the meantime they continue to pay the interim occupancy fees that they otherwise would not be incurring. This cannot continue.

Yours truly,  
Les Protopapas

---

**From:** Karen McNeill [mailto:kmcneill@harris-sheaffer.com]  
**Sent:** July-23-15 1:24 PM  
**To:** Les Protopapas  
**Cc:** Ari Katz  
**Subject:** PH4 - 144 Park

We acknowledge receipt of your letter.

24/07/2015

Please be advised that the Agreement of Purchase and Sale indicates that your client's Parking Unit will be allocated at the sole discretion of the Vendor. Accordingly, your client must relocate to their newly assignment Parking Unit on July 24, 2015 by 12:00 p.m.

Should you wish to discuss this further, please speak with Ari Katz of our office.

Karen McNeill  
Law Clerk  
[kmcneill@harris-sheaffer.com](mailto:kmcneill@harris-sheaffer.com)  
direct dial 416.250.3695

# HARRIS, SHEAFFER LLP

## BARRISTERS & SOLICITORS

Yonge Corporate Centre  
4100 Yonge Street, Suite 610, Toronto, ON M2P 2B5  
Telephone (416) 250-5800/Facsimile (416) 250-5300  
[www.harris-sheaffer.com](http://www.harris-sheaffer.com)

If you wish to be removed from any future communication from Harris Sheaffer, please send a blank email to [unsubscribe@harris-sheaffer.com](mailto:unsubscribe@harris-sheaffer.com) and you will be removed from future email correspondence within 10 business days.

*One of Canada's top 5 boutique commercial real estate firms as ranked by Canadian Lawyer Magazine*

**IMPORTANT NOTICE:** This email communication is confidential and legally privileged. If you are not the intended recipient, please notify me at the telephone number shown above or by return email and delete this communication and any copy immediately. Thank you

IN THE MATTER OF THE CONSTRUCTION LIEN ACT, R.S.O. 1990, c. C.30, AS AMENDED

AND IN THE MATTER OF AN APPLICATION MADE BY 144 PARK LTD. FOR THE APPOINTMENT OF A TRUSTEE  
UNDER SECTION 68(1) OF THE CONSTRUCTION LIEN ACT, R.S.O. 1990, c. C.30, AS AMENDED

Court File No. CV15-10843-00CL

**ONTARIO  
SUPERIOR COURT OF JUSTICE  
PROCEEDING COMMENCED AT  
TORONTO**

**AFFIDAVIT**

**DUNCAN, LINTON LLP**  
Barristers & Solicitors  
P.O. Box 457  
45 Erb Street East  
Waterloo, Ontario  
N2J 4B5

Irwin A. Duncan (LSUC #12857G)  
e: [iad@kwlaw.net](mailto:iad@kwlaw.net)

t: (519) 886-3340  
f: (519) 886-8651

Lawyers for Richard Magnussen, Marilyn Magnussen,  
Joseph Siefried, Susan Siefried, AJ Mueller, Kerry Mueller,  
Ryan Cyrankiewicz and Laurie Cyrankiewicz

TAB 4

ONTARIO  
SUPERIOR COURT OF JUSTICE  
(COMMERCIAL LIST)

IN THE MATTER OF THE *CONSTRUCTION LIEN ACT*,  
R.S.O. 1990, c. C.30, AS AMENDED

AND IN THE MATTER OF AN APPLICATION MADE BY 144 PARK LTD.  
FOR THE APPOINTMENT OF A TRUSTEE UNDER SECTION 68(1) OF THE  
*CONSTRUCTION LIEN ACT*, R.S.O. 1990, c. C.30, AS AMENED

**AFFIDAVIT**

I, Ryan Cyrankiewicz, of the City of Waterloo, in the Regional Municipality, MAKE  
OATH AND SAY:

1. I am a unit purchaser and resident of 144 Park Street, Waterloo, Ontario, and, as such, have knowledge of the matters contained in this Affidavit.
2. The matters deposed to herein are within my personal knowledge except where otherwise indicated. Where I indicate that I have obtained information from other sources, I believe that information to be true. Copies of documents attached hereto as exhibits are true copies of the documents so identified.
3. My mother, Laurie Cyrankiewicz and I entered into an Agreement of Purchase and Sale with 144 Park Ltd. ("144 Park") on January 27, 2010, to purchase Suite No. 1404 and two parking units at a purchase price of \$383,600. A copy of that Agreement is annexed as **Exhibit "A"**.
4. We initially intended to purchase this property as a long-term investment.

5. Our decision to purchase this property was based on a desire to own a high-quality condominium residence, close to the amenities of downtown Waterloo, without the concerns of property maintenance and upkeep associated with freehold ownership.

6. We entered into an Amendment to our Agreement on June 1, 2010 to change the unit we were purchasing to Suite 1504 from Suite 1404. No other changes were made to our Agreement. A copy of the Amendment is annexed as **Exhibit "B"**.

7. Two parking spaces are required to accommodate our lifestyle needs and we would not have purchased this property unless it included two parking units.

8. We paid the following deposits on account of the purchase price:

- (a) \$5,000 - upon submitting the Agreement;
- (b) \$14,180 - 21 days after execution of the Agreement;
- (c) \$19,180 - 120 days after execution of the Agreement;
- (d) \$19,180 - 180 days after execution of the Agreement;

The balance of the purchase price is payable upon Title Transfer date.

9. On or about May 9, 2014, we agreed with 144 Park to have certain upgrades incorporated into our residential unit, at a cost of \$55,002.31 of which \$27,501.00 was paid prior to taking Interim Occupancy of our Unit. The balance of the cost of those upgrades was added to the amount payable at the time we assumed Interim Occupancy. A copy of the Upgrade Sheet is annexed as **Exhibit "C"** and a copy of the Interim Statement of Adjustments is annexed as **Exhibit "D"**.



10. We also arranged for additional work to be performed in our unit as follows:

- (a) Kitchen Improvements – Casey’s Creative Kitchens Inc. - \$7,731.35
- (b) Lighting – Urban Lights Inc. - \$1,556.50; and
- (c) Shelving and storage – Space Age Shelving and Design - \$3,199.91.

Copies of the invoices from those trades are annexed as **Exhibit “E”**.

11. In accordance with the Agreement, we entered into Interim Occupancy of our residential unit and two parking units on or about September 30, 2014. At that time we paid a further deposit on account of the purchase price of \$27,501.31 in accordance with the Interim Statement of Adjustments (annexed as Exhibit “D”). We also paid \$53.50 for prorated occupancy fees and provided five post-dated cheques in the amount of \$1,605.11 each.

12. Prior to the interim occupancy date, the solicitors for the Vendor provided us with copies of the following documents:

- (a) Budget Statement for First Year of Operations;
- (b) Disclosure Statement;
- (c) Declaration;
- (d) By-Law No. 1; and
- (e) Management Agreement.

13. We signed and delivered Occupancy Acknowledgments and a Direction re Title authorizing title to our unit to be put in the name of Laurie Cyrankiewicz. Copies of the

Occupancy Acknowledgements are annexed as **Exhibit "F"** and a copy of the Direction re Title is annexed as **Exhibit "G"**.

14. The Interim Closing documentation all refer to our residential unit number as Unit 4, Level 15 and the two parking units as Unit 2, Level 3 and Unit 3, Level 3.

15. Once in occupancy, we moved our furniture and personal belongings into our unit and completed all required decorating. We incurred costs of approximately \$40,000 for decorating costs.

16. Since taking Interim Occupancy we have paid Interim Occupancy fees in the amount of \$1,605.14 per month up to and including May, 2015.

17. When we entered into Interim Occupancy, construction of the building was not completed. Work was still being performed on the common elements of the Project.

### **Trusteeship**

18. I learned about the appointment of Collins, Barrow Limited as Trustee on or about January 23, 2015.

19. My first concern was that the common elements of the Project be completed and that all steps required to attain registration of the Project as a condominium were continued so that we could complete the purchase of our unit.

## Post May 1, 2015

20. I was advised by our solicitors that they received a letter from the solicitors for the Trustee dated June 16, 2015, (a copy of which is attached as **Exhibit "H"**), advising of the registration of the condominium documents on May 25, 2015, and that the Order appointing the Trustee had been registered on January 23, 2015. The letter went on to state:

*"Unfortunately there are not sufficient parking units available to be sold in this project. Accordingly, the Court Appointed Trustee is requesting that the Purchaser(s) agree to amend the Agreement of Purchase and Sale to delete the second Parking Unit and correspondingly reduce the purchase price by the amount of \$33,900 (inclusive of HST). If your client is agreeable to same, please sign and return a copy of this letter to us by no later than June 22, 2015, and we will then be in a position to set a final closing date. If we do not hear from you by that time or your client is not agreeable to the Amendment, the Trustee may seek a Court Order terminating the Agreement of Purchase and Sale."*

21. At no time was I ever told by the Trustee that it required us to give up a parking space. In my conversations with Karla Roelofsz, I had received repeated assurances that our purchase transaction would be completed shortly after the Trustee was appointed.

22. I was advised by my solicitors that on July 21, 2015, they received a fax from Harris, Sheaffer wherein they advise that *"your client has been allocated a new Parking Unit and this allocation will take effect at noon on July 24, 2015. Your client's new Parking Unit allocation is Unit 36 Level 1"*. The letter concludes *"The Trustee intends to schedule a Title Transfer Date as soon as possible."* *Emphasis added.* A copy of that letter is annexed as **Exhibit "I"** hereto.

23. My solicitors responded to the July 21, 2015 fax from Harris Scheaffer the same day. A copy of that letter is annexed as **Exhibit “J”**.

24. The solicitors for the Vendor responded by email dated July 21, wherein they asserted that the Vendor could allocate parking spaces in its sole discretion. A copy of that email is annexed as **Exhibit “K”**.

25. Our solicitor responded by letter dated July 23, 2015, wherein he disputed the right of the Trustee to re-allocate parking units and advised that if the Trustee did not relent, that a court application would be necessary. A copy of that letter is annexed as **Exhibit “L”**.

26. I was advised by our solicitor that he received an email from the Vendor’s lawyers on July 23, 2015, wherein they re-asserted the right of the Trustee to re-allocate parking units. A copy of that email is annexed as **Exhibit “M”**.

27. I am advised by my solicitor that he received an email from the Vendor’s lawyers on August 6, 2015, concerning the parking unit re-allocation. The Re line of that email states: **“Urgent notice of postponement of final closing \*\*PLEASE ADVISE YOUR CLIENT AND YOUR CLIENT’S LENDER\*\*”** and advised that the Trustee would be bringing a motion concerning the issue on August 18, 2015. A copy of that email is annexed as **Exhibit “N”**.

28. By email dated August 27, 2015, the solicitor for the Trustee advised that a motion for advice and directions would be brought by the Trustee to obtain authority to re-allocate

parking units and to terminate Agreements of Purchase and Sale with purchasers who have two parking spots. Attached as **Exhibit 'O'** is a true copy of that email.

29. I am very concerned that the loss of a parking unit would have reduced the value of our condominium. I also do not consider the Trustee's offer of a \$33,900 reduction in the purchaser price for our residential unit to be adequate compensation for the loss of a parking unit, let alone compensation for the reduction in value of our residential unit.

30. The loss of a parking space would significantly affect our use and enjoyment of our condominium unit. We would have no place to park our second vehicle. The 144 Park Project has no visitor parking spaces and therefore storage of, and access to, our second vehicle would be very problematic.

I make this Affidavit to provide information relating the purchase of my condominium unit and the impact of the Trustee's proposals on me and my family.

**SWORN BEFORE ME** at the City of  
Waterloo, in the Regional Municipality of  
Waterloo, on October 14, 2015.

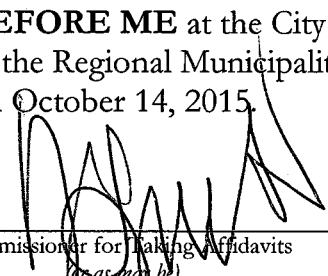
  
\_\_\_\_\_  
Commissioner for Taking Affidavits  
*(as may be)*

  
\_\_\_\_\_  
**RYAN CYRANKIEWICZ**

This is Exhibit "A" referred to in the Affidavit of  
Ryan Cyrankiewicz sworn October 14, 2015

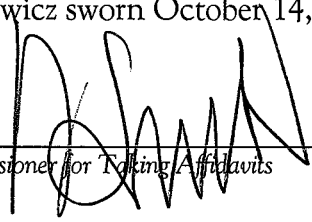

---

*Commissioner for Taking Affidavits*



**AGREEMENT OF PURCHASE AND SALE**

The undersigned, Laurie and Ryan Cvrankiewicz (collectively, the "Purchaser"), hereby agrees with 144 PARK LTD. (the "Vendor") to purchase the above-noted unit, as outlined for identification purposes only on the sketch attached hereto as Schedule "A", together with two (2) Parking Unit(s) and one (1) Locker Unit(s), all of which shall be allocated by the Vendor in its sole discretion being (a) proposed unit(s) in the Condominium, to be registered against those lands and premises situate on the north east corner of Allen Street and Park Street in the City of Waterloo, and which is proposed to be municipally known as 144 Park Street, Waterloo, Ontario (hereinafter called the "Property"), together with an undivided interest in the common elements appurtenant to such unit(s) and the exclusive use of those parts of the common elements attaching to such unit(s), as set out in the proposed Declaration (collectively, the "Unit") on the following terms and conditions:

The purchase price of the Unit (the "Purchase Price") is Three hundred eighty three thousand and six hundred. (\$383,600.00) DOLLARS in lawful money of Canada, payable as follows:

- (a) to Harris, Sheaffer LLP, in Trust, (the "Vendor's Solicitors" or "Escrow Agent" or "Trustee") in the following amounts at the following times, by cheque or bank draft, as deposits pending completion or other termination of this Agreement and to be credited on account of the Purchase Price on the Occupancy Date:
    - (i) the sum of FIVE THOUSAND (\$5,000.00) Dollars submitted with this Agreement;
    - (ii) the sum of fourteen thousand one hundred and eighty. (\$14,180.00) Dollars submitted with this Agreement and post-dated twenty one (21) days following the date of execution of this Agreement by the Purchaser, and together with 1(a)(i) above represents 5% of the Purchase Price;
    - (iii) the sum of Nineteen thousand one hundred and eighty. (\$19,180.00) Dollars submitted with this Agreement and post-dated one hundred twenty (120) days following the date of execution of this Agreement by the Purchaser, being 5% of the Purchase Price;
    - (iv) the sum of Nineteen thousand one hundred and eighty. (\$19,180.00) Dollars submitted with this Agreement and post-dated one hundred eighty (180) days following the date of execution of this Agreement by the Purchaser, being 5% of the Purchase Price;
  - (b) the sum of ZERO (\$0.00) Dollars by certified cheque or bank draft to the Vendor's Solicitors on the Occupancy Date, being 5% of the Purchase Price;
  - (c) the balance of the Purchase Price by certified cheque on the Title Transfer Date to the Vendor or as the Vendor may direct, subject to the adjustments hereinafter set forth.
  - (d) the Purchaser agrees to pay the sum as hereinbefore set out in paragraph 1 (a) as a deposit by cheque payable to the Escrow Agent with such last-mentioned party to hold such funds in trust as the escrow agent acting for and on behalf of TWC under the provisions of a Deposit Trust Agreement ("DTA") with respect to this proposed condominium on the express understanding and agreement that as soon as prescribed security for the said deposit money has been provided in accordance with Section 81 of the Act, the Escrow Agent shall be entitled to release and disburse said funds to the Vendor (or to whomsoever and in whatsoever manner the Vendor may direct).
1. (a) The Purchaser shall occupy the Unit on the First Tentative Occupancy Date [as defined in the Statement of Critical Dates being part of the Taron Addendum as hereinafter defined], or such extended or accelerated date that the Unit is substantially completed by the Vendor for occupancy by the Purchaser in accordance with the terms of this Agreement including, without limitation, the Taron Addendum (the "Occupancy Date");
- (b) The transfer of title to the Unit shall be completed on the later of the Occupancy Date or a date established by the Vendor in accordance with Paragraph 14 hereof (the "Title Transfer Date");
- (c) The Purchaser's address for delivery of any notices pursuant to this Agreement or the Act is the address set out in the Taron Addendum;
- (d) Notwithstanding anything contained in this Agreement (or in any schedules annexed hereto) to the contrary, it is expressly understood and agreed that if the Purchaser has not executed and delivered to the Vendor or its sales representative an acknowledgement of receipt of both the Vendor's disclosure statement and a copy of this Agreement duly executed by both parties hereto, within fifteen (15) days from the date of the Purchaser's execution of this Agreement as set out below, then the Purchaser shall be deemed to be in default hereunder and the Vendor shall have the unilateral right to terminate the Agreement at any time thereafter upon delivering written notice confirming such termination to the Purchaser, whereupon the Purchaser's initial deposit cheque shall be forthwith returned to the Purchaser by or on behalf of the Vendor.

The following Schedules of this Agreement, if attached hereto, shall form a part of this Agreement. If there is a form of Acknowledgement attached hereto same shall form part of this Agreement and shall be executed by the Purchaser and delivered to the Vendor on the Closing Date. The Purchaser acknowledges that he has read all Sections and Schedules of this Agreement and the form of Acknowledgement, if any:

- Schedule "A" - Unit Plan/sketch
- Schedule "B" - Features & Finishes
- Schedule "C" - Occupancy Licence
- Schedule "D" - Warning Provisions
- Schedule "E" - Receipt Confirmation
- Schedule being the Taron Warranty Corporation Statement of Critical Dates and Addendum to Agreement of Purchase and Sale (collectively the "Taron Addendum") and such other Schedules annexed hereto and specified as Schedule " ".

DATED, signed, sealed and delivered this 27th day of JANUARY, 20010

SIGNED, SEALED AND DELIVERED in the presence of  
[Signature]  
WITNESS (as to all Purchaser's signatures, if more than one purchaser)

[Signature] PURCHASER D.O.B. Jan 12/58  
[Signature] PURCHASER D.O.B. Dec 28/81  
PURCHASER'S SOLICITOR: \_\_\_\_\_  
Address: \_\_\_\_\_  
Telephone: \_\_\_\_\_ Facsimile: \_\_\_\_\_

The undersigned accepts the above offer and agrees to complete this transaction in accordance with the terms thereof.  
DATED, signed, sealed and delivered, this 27 day of January, 20010

Vendor's Solicitors:  
HARRIS, SHEAFFER LLP  
Suite 610 - 4100 Yonge Street  
Toronto, Ontario, M2P 3B5  
Attn: Mark L. KAROLY  
Telephone: (416) 250-5800 Fax: (416) 250-5300

144 PARK LTD.  
Per: [Signature]  
Authorized Signing Officer  
I have the authority to bind the Corporation.

3. The meaning of words and phrases used in this Agreement and its Schedules shall have the meaning ascribed to them in the *Condominium Act, 1998*, S.O. 1998, C.19, the regulations thereunder and any amendments thereto (the "Act") and other terms used herein shall have ascribed to them the definitions in the Condominium Documents unless otherwise provided for as follows:
- (a) "Agreement" means this Agreement of Purchase and Sale including all Schedules attached hereto and made a part hereof;
  - (b) "Condominium" means the condominium which will be registered against the Property pursuant to the provisions of the Act;
  - (c) "Condominium Documents" means the Creating Documents, the by-laws and rules of the Condominium, the disclosure statement and budget statement together with all other documents and agreements which are entered into by the Vendor on behalf of the Condominium or by the Condominium directly prior to the turnover of the condominium, as may be amended from time to time;
  - (d) "CRA" means the Canada Revenue Agency or its successors;
  - (e) "Creating Documents" means the declaration and description which are intended to be registered against title to the Property and which will serve to create the Condominium, as may be amended from time to time;
  - (f) "Interim Occupancy" shall mean the period of time from the Occupancy Date to the Title Transfer Date;
  - (g) "Occupancy Licence" shall mean the terms and conditions by which the Purchaser shall occupy the Unit during Interim Occupancy as set forth in Schedule "C" hereof;
  - (h) "Occupancy Fee" shall mean the sum of money payable monthly in advance by the Purchaser to the Vendor and calculated in accordance with Schedule "C" hereof;
  - (i) "Property" shall mean the lands and premises upon which the Condominium is constructed or shall be constructed and legally described in the Condominium Documents; and
  - (j) "TWC" means Taron Warranty Corporation or its successors.

**Finishes**

4. The Purchase Price shall include those items listed on Schedule "B" attached hereto. The Purchaser acknowledges that only the items set out in Schedule "B" are included in the Purchase Price and that model suite/vingette furnishings and appliances, decor, upgrades, artist's renderings, scale model(s), improvements, mirrors, drapes, tracks and wall coverings are for display purposes only and are not included in the Purchase Price unless specified in Schedule "B". The Purchaser agrees to attend and notify the Vendor of his/her choice of finishes within fifteen (15) days of being requested to do so by the Vendor. In the event colours and/or finishes subsequently become unavailable, the Purchaser agrees to re-attend at such time or times as requested by the Vendor or its agents, to choose from substitute colours and/or finishes. If the Purchaser fails to choose colours or finishes within the time periods requested, the Vendor may irrevocably choose the colours and finishes for the Purchaser and the Purchaser agrees to accept the Vendor's selections.

**Deposits**

5. (a) The Vendor shall credit the Purchaser with interest at the prescribed rate on either the Occupancy Date or Title Transfer Date at the Vendor's sole discretion on all money received by the Vendor on account of the Purchase Price from the date of deposit of the money received from time to time by the Declarant's solicitor or the trustee until the Occupancy Date. The Purchaser acknowledges and agrees that, for the purposes of subsection 81(6) of the Act, compliance with the requirement to provide written evidence, in the form prescribed by the Act, of payment of monies by or on behalf of the Purchaser on account of the Purchase Price of the Unit shall be deemed to have been sufficiently made by delivery of such written evidence to the address of the Purchaser noted in the Taron Addendum. The Purchaser further acknowledges and agrees that any cheques provided to the Vendor on account of the Purchase Price will not be deposited and accordingly interest as prescribed by the Act will not accrue thereon, until after the expiry of the ten (10) day rescission period as provided for in section 73 of the Act (or any extension thereof as may be agreed to in writing by the Vendor). The Purchaser represents and warrants that the Purchaser is not a non-resident of Canada within the meaning of the Income Tax Act of Canada (the "ITA"). If the Purchaser is not a resident of Canada for the purposes of the ITA the Vendor shall be entitled to withhold and remit to CRA the appropriate amount of interest payable to the Purchaser on account of the deposits paid hereunder, under the ITA.
- (b) All deposits paid by the Purchaser shall be held by the Escrow Agent in a designated trust account, and shall be released only in accordance with the provisions of subsection 81(7) of the Act and the regulations thereto, as amended. Without limiting the generality of the foregoing, and for greater clarity, it is understood and agreed that with respect to any deposit monies received from the Purchaser the Escrow Agent shall be entitled to withdraw such deposit monies from said designated trust account prior to the Title Transfer Date if and only when the Vendor obtains a Certificate of Deposit from TWC for deposit monies up to Twenty Thousand (\$20,000.00) Dollars and with respect to deposit monies in excess of Twenty Thousand (\$20,000.00) Dollars, one or more excess condominium deposit insurance policies (issued by any insurer as may be selected by the Vendor, authorized to provide excess condominium deposit insurance in Ontario) insuring the deposit monies so withdrawn (or intended to be withdrawn), and delivers the said excess condominium deposit insurance policies (duly executed by or on behalf of the insurer and the Vendor) to the Escrow Agent holding the deposit monies for which said policies have been provided as security, in accordance with the provisions of section 21 of O. Reg. 48/01.

**Adjustments**

6. (a) Commencing as of the Occupancy Date, the Purchaser shall be responsible and be obligated to pay the following costs and/or charges in respect to the Unit:

- (i) all utility costs including electricity, gas and water (unless included as part of the common expenses); and
  - (ii) the Occupancy Fee owing by the Purchaser for Interim Occupancy prior to the Title Transfer Date (if applicable).
- (b) The Purchase Price shall be adjusted to reflect the following items, which shall be apportioned and allowed from the Title Transfer Date, with that day itself apportioned to the Purchaser:
- (i) realty taxes (including local improvement charges pursuant to the *Local Improvement Charges Act*, if any) which may be estimated as if the Unit has been assessed as fully completed by the taxing authority for the calendar year in which the transaction is completed as well as for the following calendar year, notwithstanding the same may not have been levied or paid on the Title Transfer Date. The Vendor shall be entitled in its sole discretion to collect from the Purchaser a reasonable estimate of the taxes as part of the Occupancy Fee and/or such further amounts on the Title Transfer Date, provided all amounts so collected shall either be remitted to the relevant taxing authority on account of the Unit or held by the Vendor pending receipt of final tax bills for the Unit, following which said realty taxes shall be readjusted in accordance with subsections 80(8) and (9) of the Act; and
  - (ii) common expense contributions attributable to the Unit, with the Purchaser being obliged to provide the Vendor on or before the Title Transfer Date with a series of post-dated cheques payable to the condominium corporation for the common expense contributions attributable to the Unit, for such period of time after the Title Transfer Date as determined by the Vendor (but in no event for more than one year);
- (c) Interest on all money paid by the Purchaser on account of the Purchase Price, shall be adjusted and credited to the Purchaser in accordance with paragraph 5 of this Agreement.
- (d) The Purchaser shall, in addition to the Purchase Price, pay the following amounts to the Vendor on the Title Transfer Date:
- (i) If there are chattels involved in this transaction, the allocation of value of such chattels shall be estimated where necessary by the Vendor and retail sales tax may be collected and remitted by the Vendor or alternatively, the Purchaser shall pay as a credit to the Vendor on the Statement of Adjustments, the provincial sales tax paid by the Vendor on account of chattels in Schedule "B";
  - (ii) Any new taxes imposed on or payable in respect to the purchase of the Unit by the federal, provincial, or municipal government or any increases to existing taxes currently imposed on the Unit by such government;
  - (iii) The amount of any parks levy levied, charged or otherwise imposed with respect to the Condominium, the Property or the Unit by any governmental authority, not to exceed One Thousand Five Hundred (\$1,500.00) Dollars plus G.S.T. per unit;
  - (iv) The cost of the TWC enrolment fee for the Unit (together with any provincial or federal taxes exigible with respect thereto);
  - (v) The cost of utility meters, water meter installations, hydro and gas meter or check meter installations, water and sewer service connection charges and hydro and gas installation and connection or energization charges for the Condominium and/or the Unit, the Purchaser's portion of such installation and/or connection or energization charges and costs to be calculated by dividing the total amount of such charges and costs by the number of residential dwelling units in the Condominium and by charging the Purchaser in the statement of adjustments with that portion of the charges and costs;
  - (vi) The cost of any carbon monoxide detector installed in the Unit (if applicable);
  - (vii) The charge imposed upon the Vendor or its solicitors by the Law Society of Upper Canada upon registration of a Transfer/Deed of Land or Charge/Mortgage of Land or any other instrument;
  - (viii) A sum of Fifty (\$50.00) Dollars for each cheque tendered pursuant to paragraph 1(a) and 1(b) of this Agreement and for any cheque tendered for upgrades or any other monies paid on account of the Purchase Price up to, but not including the Title Transfer Date representing a reasonable reimbursement to the Vendor of the costs incurred or to be incurred by the Vendor in fulfillment of the requirements of subsection 81(6) of the Act;
  - (ix) The Purchaser agrees to pay Three Hundred (\$300.00) Dollars towards the cost of obtaining (partial) discharges of mortgages not intended to be assumed by the Purchaser;
- (e) In the event that the Purchaser desires to increase the amount to be paid to the Vendor's solicitors on the Occupancy Date at any time after the expiry of the initial ten (10) day statutory rescission period, or wishes to vary the manner in which the Purchaser has previously requested to take title to the Property, or wishes to add or change any unit(s) being acquired from the Vendor, then the Purchaser hereby covenants and agrees to pay to the Vendor's Solicitor's the legal fees and ancillary disbursements which may be incurred by the Vendor or charged by the Vendor's Solicitors in order to implement any of the foregoing changes so requested by the Purchaser (with the Vendor's Solicitors' legal fees for implementing any such changes to any of the interim closing and/or final closing documents so requested by the Purchaser and agreed to by the Vendor being \$350.00 plus G.S.T.), but without there being any obligation whatsoever on the part of the Vendor to approve of, or to implement, any of the foregoing changes so requested.

- (f) It is further understood and agreed that the Unit may include a rental or leased furnace or hot water tank or HVAC equipment and associated components which would remain the property of the appropriate company or other supplier of such item, and in such event and where the cost of same does not comprise a common expense of the Condominium, the Purchaser shall pay the monthly rental/lease charges assessed with respect thereto from and after the Occupancy Date, and in any event shall execute all requisite rental or security documents in connection therewith.
- (g) The Purchaser acknowledges that it may be required to enter into an agreement with the supplier of hydro services to the Condominium (the "Hydro Supplier") on or before the Closing Date. Furthermore, the Purchaser acknowledges that such agreement may require the Purchaser to deliver a security deposit to the Hydro Supplier prior to the Occupancy Date and the Purchaser agrees to deliver such security deposit to the Vendor on the Occupancy Date.
- (h) It is acknowledged and agreed by the parties hereto that the Purchase Price already includes a component equivalent to both the federal portion and, if applicable, the provincial portion of the harmonized goods and services tax or single sales tax exigible with respect to this purchase and sale transaction less the Rebate as defined below (hereinafter referred to as the "HST"), and that the Vendor shall remit the HST to CRA on behalf of the Purchaser forthwith following the completion of this transaction. The Purchaser hereby warrants and represents to the Vendor that with respect to this transaction, the Purchaser qualifies for the new housing rebate applicable pursuant to Section 254 of the *Excise Tax Act* (Canada), as may be amended, and the new housing rebate announced by the Ontario Ministry of Revenue (collectively, the "Rebate"), in its Information Notice dated June 2009 – No. 2 (the "Ontario Circular") and further warrants and represents that the Purchaser is a natural person who is acquiring the Property with the intention of being the sole beneficial owner thereof on the Title Transfer Date (and not as the agent or trustee for or on behalf of any other party or parties), and covenants that upon the Occupancy Date the Purchaser or one or more of the Purchaser's relations (as such term is defined in the *Excise Tax Act*) shall personally occupy the Unit as his primary place of residence, for such period of time as shall be required by the *Excise Tax Act*, and any other applicable legislation, in order to entitle the Purchaser to the Rebate (and the ultimate assignment thereof to and in favour of the Vendor) in respect of the Purchaser's acquisition of the Unit. The Purchaser further warrants and represents that he has not claimed (and hereby covenants that the Purchaser shall not hereafter claim), for the Purchaser's own account, any part of the Rebate or the RST transitional housing rebate referred to in the Ontario Circular (the "Transitional Rebate") in connection with the Purchaser's acquisition of the Unit, save as otherwise hereinafter expressly provided or contemplated. The Purchaser hereby irrevocably assigns to the Vendor all of the Purchaser's rights, interests and entitlements to the Rebate and the Transitional Rebate (and concomitantly releases all of the Purchaser's claims or interests in and to the Rebate and the Transitional Rebate, to and in favour of the Vendor), and hereby irrevocably authorizes and directs CRA to pay or credit the Rebate and the Transitional Rebate directly to the Vendor. In addition, the Purchaser shall execute and deliver to the Vendor, forthwith upon the Vendor's or Vendor's solicitors request for same (and in any event on or before the Title Transfer Date), all requisite documents and assurances that the Vendor or the Vendor's solicitors may reasonably require in order to confirm the Purchaser's entitlement to the Rebate and/or to enable the Vendor to obtain the benefit of the Rebate and the Transitional Rebate (by way of assignment or otherwise), including without limitation, the New Housing Application for Rebate of Goods and Services Tax Form as prescribed from time to time (the "Rebate Forms"). The Purchaser covenants and agrees to indemnify and save the Vendor harmless from and against any loss, cost, damage and/or liability (including an amount equivalent to the Rebate and the Transitional Rebate, plus penalties and interest thereon) which the Vendor may suffer, incur or be charged with, as a result of the Purchaser's failure to qualify for the Rebate, or as a result of the inability to assign the benefit of the Rebate or the Transitional Rebate to the Vendor (or the ineffectiveness of the documents purporting to assign the benefit of the Rebate or the Transitional Rebate to the Vendor). As security for the payment of such amount, the Purchaser does hereby charge and pledge his interest in the Unit with the intention of creating a lien or charge against same. It is further understood and agreed by the parties hereto that:

- (i) if the Purchaser does not qualify for the Rebate, or fails to deliver to the Vendor or the Vendor's solicitors forthwith upon the Vendor's or the Vendor's solicitors request for same (and in any event on or before the Title Transfer Date) the Rebate Forms duly executed by the Purchaser, together with all other requisite documents and assurances that the Vendor or the Vendor's solicitors may reasonably require from the Purchaser or the Purchaser's solicitor in order to confirm the Purchaser's eligibility for the Rebate and/or to ensure that the Vendor ultimately acquires (or is otherwise assigned) the benefit of the Rebate and the Transitional Rebate; or
- (ii) if the Vendor believes, for whatever reason, that the Purchaser does not qualify for the Rebate, regardless of any documentation provided by or on behalf of the Purchaser (including any statutory declaration sworn by the Purchaser) to the contrary, and the Vendor's belief or position on this matter is communicated to the Purchaser or the Purchaser's solicitor on or before the Title Transfer Date;

then notwithstanding anything hereinbefore or hereinafter provided to the contrary, the Purchaser shall be obliged to pay to the Vendor (or to whomsoever the Vendor may in writing direct), by certified cheque delivered on the Title Transfer Date, an amount equivalent to the Rebate and/or the Transitional Rebate, in addition to the Purchase Price and in those circumstances where the Purchaser maintains that he is eligible for the Rebate despite the Vendor's belief to the contrary, the Purchaser shall (after payment of the amount equivalent to the Rebate as aforesaid) be fully entitled to pursue the procurement of the Rebate directly from CRA. It is further understood and agreed that in the event that the Purchaser intends to rent out the Unit before or after the Title Transfer Date, the Purchaser shall not be entitled to the Rebate, but may nevertheless be entitled to pursue, on his own after the Title Transfer Date, the federal and provincial new rental housing rebates directly with CRA, pursuant to Section 256.2 of the *Excise Tax Act*, as may be amended, and other applicable legislation to be enacted relating to the provincial new rental housing rebate.

- (i) Notwithstanding any other provision herein contained in this Agreement, the Purchaser acknowledges and agrees that the Purchase Price does not include any HST exigible with respect to any of the adjustments payable by the Purchaser pursuant to this Agreement, or any extras or upgrades or changes purchased, ordered or chosen by the Purchaser from the Vendor which are not specifically set forth in this Agreement,

and the Purchaser covenants and agrees to pay such HST to the Vendor in accordance with the *Excise Tax Act*. In addition, and without limiting the generality of the foregoing, in the event that the Purchase Price is increased by the addition of extras, changes, upgrades or adjustments and as a result of such increase, the quantum of the Rebate that would otherwise be available is reduced or extinguished (the quantum of such reduction being hereinafter referred to as the "Reduction"), then the Purchaser shall pay to the Vendor on the Title Transfer Date the amount of (as determined by the Vendor in its sole and absolute discretion) the Reduction.

- (j) An administration fee of TWO HUNDRED AND FIFTY (\$250.00) DOLLARS shall be charged to the Purchaser for any cheque payable hereunder delivered to the Vendor or to the Vendor's Solicitors and not accepted by the Vendor's or the Vendor's Solicitor's bank for any reason. At the Vendor's option, this administration fee can be collected as an adjustment on the Title Transfer Date or together with the replacement cheque delivered by the Purchaser.

Title

7. The Vendor or its Solicitor shall notify the Purchaser or his/her Solicitor following registration of the Creating Documents so as to permit the Purchaser or his/her Solicitor to examine title to the Unit (the "Notification Date"). The Purchaser shall be allowed twenty (20) days from the Notification Date (the "Examination Period") to examine title to the Unit at the Purchaser's own expense and shall not call for the production of any surveys, title deeds, abstracts of title, grading certificates, occupancy permits or certificates, nor any other proof or evidence of the title or occupiability of the Unit, except such copies thereof as are in the Vendor's possession. If within the Examination Period, any valid objection to title or to any outstanding work order is made in writing to the Vendor which the Vendor shall be unable or unwilling to remove and which the Purchaser will not waive, this Agreement shall, notwithstanding any intervening acts or negotiations in respect of such objections, be null and void and the deposit monies together with the interest required by the Act to be paid after deducting any payments due to the Vendor by the Purchaser as provided for in this Agreement shall be returned to the Purchaser and the Vendor shall have no further liability or obligation hereunder and shall not be liable for any costs or damages. Save as to any valid objections so made within the Examination Period, the Purchaser shall be conclusively deemed to have accepted the title of the Vendor to the Unit. The Purchaser acknowledges and agrees that the Vendor shall be entitled to respond to some or all of the requisitions submitted by or on behalf of the Purchaser through the use of a standard title memorandum or title advice statement prepared by the Vendor's Solicitors, and that same shall constitute a satisfactory manner of responding to the Purchaser's requisitions, thereby relieving the Vendor and the Vendor's Solicitors of the requirement to respond directly or specifically to the Purchaser's requisitions.

Direction Re: Title

8. The Purchaser hereby agrees to submit to the Vendor or the Vendor's Solicitors on the earlier of the Occupancy Date and twenty (20) days prior to the Title Transfer Date, a written direction as to how the Purchaser intends to take title to the Unit, including, the date(s) of birth and marital status and the Purchaser shall be required to close the transaction in the manner so advised unless the Vendor otherwise consents in writing, which consent may be arbitrarily withheld. If the Purchaser does not submit such confirmation within the required time as aforesaid the Vendor shall be entitled to tender a Transfer/Deed on the Title Transfer Date engrossed in the name of the Purchaser as shown on the face of this Agreement.

Permitted Encumbrances

9. (a) The Purchaser agrees to accept title subject to the following:
- (i) the Condominium Documents, notwithstanding that they may be amended and varied from the proposed Condominium Documents in the general form attached to the Disclosure Statement delivered to the Purchaser as set out in Schedule "E";
  - (ii) registered restrictions or covenants that run with the Property, including any encroachment agreement(s) with any governmental authorities or adjacent land owner(s), provided that same are complied with as at the Title Transfer Date;
  - (iii) easements, rights-of-way and/or licences now registered (or to be registered hereafter) for the supply and installation of utility services, drainage, telephone services, electricity, gas, storm and/or sanitary sewers, water, cable television/internet, recreational and shared facilities, and/or any other service(s) to or for the benefit of the Condominium (or to any adjacent or neighbouring properties), including any easement(s) which may be required by the Vendor (or by the owner of the Property, if not one and the same as the Vendor), or by any owner(s) of adjacent or neighbouring properties, for servicing and/or access to (or entry from) such properties, together with any easement and cost-sharing agreement(s) or reciprocal agreement(s) confirming (or pertaining to) any easement or right-of-way for access, egress, support and/or servicing purposes, and/or pertaining to the sharing of any services, facilities and/or amenities with adjacent or neighbouring property owners, provided that any such easement and cost-sharing agreements or reciprocal agreements are (insofar as the obligations thereunder pertaining to the Property, or any portion thereof, are concerned) complied with as at the Title Transfer Date;
  - (iv) registered municipal agreements and registered agreements with publicly regulated utilities and/or with local ratepayer associations, including without limitation, any development, site plan, condominium, subdivision, Section 37, collateral, limiting distance, engineering and/or other municipal agreement (or similar agreements entered into with any governmental authorities including any amendments or addenda related thereto), (with all of such agreements being hereinafter collectively referred to as the "Development Agreements"), provided that same are complied with as at the Title Transfer Date, or security has been posted in such amounts and on such terms as may be required by the governmental authorities to ensure compliance therewith and/or the completion of any outstanding obligations thereunder; and
  - (v) unregistered or inchoate liens for unpaid utilities in respect of which no formal bill, account or invoice has been issued by the relevant utility authority (or if issued, the time for payment of same

has not yet expired), without any claim or request by the Purchaser for any utility holdback(s) or reduction/abatement in the Purchase Price, provided that the Vendor delivers to the Purchaser the Vendor's written undertaking to pay all outstanding utility accounts owing with respect to the Property (including any amounts owing in connection with any final meter reading(s) taken on or immediately prior to the Title Transfer Date, if applicable), as soon as reasonably possible after the completion of this transaction;

- (b) It is understood and agreed that the Vendor shall not be obliged to obtain or register on title to the property a release of (or an amendment to) any of the aforementioned easements, Development Agreements, reciprocal agreements or restrictive covenants or any of the other aforementioned agreements or notices, nor shall the Vendor be obliged to have any of same deleted from the title to the Property, and the Purchaser hereby expressly acknowledges and agrees that the Purchaser shall satisfy himself or herself as to compliance therewith. The Purchaser agrees to observe and comply with the terms and provisions of the Development Agreements, and all restrictive covenants registered on title. The Purchaser further acknowledges and agrees that the retention by the local municipality within which the Property is situate (the "Municipality"), or by any of the other governmental authorities, of security (e.g. in the form of cash, letters of credit, a performance bond, etc., satisfactory to the Municipality and/or any of the other governmental authorities) intended to guarantee the fulfilment of any outstanding obligations under the Development Agreements shall, for the purposes of the purchase and sale transaction contemplated hereunder, be deemed to be satisfactory compliance with the terms and provisions of the Development Agreements. The Purchaser also acknowledges that the wires, cables and fittings comprising the cable television system serving the Condominium are (or may be) owned by the local cable television supplier, or by a company associated, affiliated with or related to the Vendor.
- (c) The Purchaser covenants and agrees to consent to the matters referred to in subparagraph 9(a) hereof and to execute all documents and do all things requisite for this purpose, either before or after the Title Transfer Date;
- (d) In the event that the Vendor is not the registered owner of the Property, the Purchaser agrees to accept a conveyance of title from the registered owner together with the owner's title covenants in lieu of the Vendor's.
- (e) The Vendor shall be entitled to insert in the Transfer/Deed of Land, specific covenants by the Purchaser pertaining to any or all of the restrictions, easements, covenants and agreements referred to herein and in the Condominium Documents, and in such case, the Purchaser may be required to deliver separate written covenants on closing. If so requested by the Vendor, the Purchaser covenants to execute all documents and instruments required to convey or confirm any of the easements, licences, covenants, agreements, and/or rights, required pursuant to this Agreement and shall observe and comply with all of the terms and provisions therewith. The Purchaser may be required to obtain a similar covenant (enforceable by and in favour of the Vendor), in any agreement entered into between the Purchaser and any subsequent transferee of the Unit.

#### Vendor's Lien

- 10. The Purchaser agrees that the Vendor shall have a Vendor's Lien for unpaid purchase monies on the Title Transfer Date and shall be entitled to register a Notice of Vendor's Lien against the Unit any time after the Title Transfer Date.

#### Partial Discharges

- 11. The Purchaser acknowledges that the Unit may be encumbered by mortgages (and collateral security thereto) which are not intended to be assumed by the Purchaser and that the Vendor shall not be obliged to obtain and register (partial) discharges of such mortgages insofar as they affect the Unit on the Title Transfer Date. The Purchaser agrees to accept the Vendor's Solicitors' undertaking to obtain and register (partial) discharges of such mortgages in respect of the Unit, as soon as reasonably possible after the Title Transfer Date subject to the Vendor or its solicitors providing to the Purchaser or the Purchaser's Solicitor the following:
  - (a) a mortgage statement or letter from the mortgagee(s) (or from their respective solicitors) confirming the amount, if any, required to be paid to the mortgagee(s) to obtain (partial) discharges of the mortgages with respect to the Unit;
  - (b) a direction from the Vendor to the Purchaser to pay such amounts to the mortgagee(s) (or to whomever the mortgagees may direct) on the Title Transfer Date to obtain a (partial) discharge of the mortgage(s) with respect to the Unit; and
  - (c) an undertaking from the Vendor's Solicitors to deliver such amounts to the mortgagees and to obtain and register the (partial) discharge of the mortgages with respect to the Unit upon receipt thereof and within a reasonable time following the Title Transfer Date and to advise the Purchaser or the Purchaser's Solicitor concerning registration particulars by posting same on the internet.

#### Construction Lien Act

- 12. The Purchaser covenants and agrees that he/she is a "home buyer" within the meaning of the *Construction Lien Act*, R.S.O. 1990, c.C.30 and will not claim any lien holdback on the Occupancy Date or Title Transfer Date. The Vendor shall complete the remainder of the Condominium according to its schedule of completion and neither the Occupancy Date nor the Title Transfer Date shall be delayed on that account.

#### The Planning Act

- 13. This Agreement and the transaction arising therefrom are conditional upon compliance with the provisions of section 50 of the *Planning Act*, R.S.O. 1990, c.P.13 and any amendments thereto on or before the Title Transfer Date.

Title Transfer Date

14. (a) The provisions of the Tarion Addendum reflect the TWC's policies, regulations and/or guidelines on extensions of the First Tentative Occupancy Date, but it is expressly understood and agreed by the parties hereto that any failure to provide notice(s) of the extension(s) of the First Tentative Occupancy Date. Subsequent Tentative Occupancy Dates or Firm Occupancy Date, in accordance with the provisions of the Tarion Addendum shall only give rise to a damage claim by the Purchaser against the Vendor up to a maximum of \$7,500.00, as more particularly set forth in the Regulations to the *Ontario New Home Warranties Plan Act*, R.S.O. 1990, as amended (the "ONHWA"), and under no circumstances shall the Purchaser be entitled to terminate this transaction or otherwise rescind this Agreement as a result thereof, other than in accordance with the Tarion Addendum.
- (b) The Vendor's Solicitors shall designate a date not less than twenty (20) days after written notice is given to the Purchaser or his or her solicitor of the registration of the Creating Documents as the Title Transfer Date. The Title Transfer Date once designated may be extended from time to time by the Vendor's Solicitors provided that it shall not be more than twenty-four (24) months following the Occupancy Date.

Purchaser's Covenants, Representations and Warranties

15. The Purchaser covenants and agrees that this Agreement is subordinate to and postponed to any mortgages arranged by the Vendor and any advances thereunder from time to time, and to any easement, license or other agreement concerning the Condominium and the Condominium Documents. The Purchaser further agrees to consent to and execute all documentation as may be required by the Vendor in this regard and the Purchaser hereby irrevocably appoints the Vendor as the Purchaser's attorney to execute any consents or other documents required by the Vendor to give effect to this paragraph. The Purchaser hereby consents to the Vendor obtaining a consumer's report containing credit and/or personal information for the purposes of this transaction. The Purchaser further agrees to deliver to the Vendor, from time to time, within ten (10) days of written demand from the Vendor, all necessary financial and personal information required by the Vendor in order to evidence the Purchaser's ability to pay the balance of the Purchase Price on the Title Transfer Date, including without limitation, written confirmation of the Purchaser's income and evidence of the source of the payments required to be made by the Purchaser in accordance with this Agreement. Without limiting the generality of the foregoing and notwithstanding any other provision in this Agreement to the contrary, within ten (10) days of written demand from the Vendor, the Purchaser agrees to produce evidence of a satisfactory mortgage approval signed by a lending institution or other mortgagee acceptable to the Vendor confirming that the said lending institution or acceptable mortgagee will be advancing funds to the Purchaser sufficient to pay the balance due on the Title Transfer Date. If the Purchaser fails to provide the mortgage approval as aforesaid, then the Purchaser shall be deemed to be in default under this Agreement. The Vendor may, in its sole discretion, elect to accept in the place of such mortgage commitment, other evidence satisfactory to the Vendor that the Purchaser will have sufficient funds to pay the balance due on the Title Transfer Date.
16. The Purchaser acknowledges that notwithstanding any rule of law to the contrary, that by executing this Agreement, it has not acquired any equitable or legal interest in the Unit or the Property. The Purchaser covenants and agrees not to register this Agreement or notice of this Agreement or a caution, certificate of pending litigation, Purchaser's Lien, or any other document providing evidence of this Agreement against title to the Property, Unit or the Condominium and further agrees not to give, register, or permit to be registered any encumbrance against the Property, Unit or the Condominium. Should the Purchaser be in default of his or her obligations hereunder, the Vendor may, as agent and attorney of the Purchaser, cause the removal of notice of this Agreement, caution or other document providing evidence of this Agreement or any assignment thereof, from the title to the Property, Unit or the Condominium. In addition, the Vendor, at its option, shall have the right to declare this Agreement null and void in accordance with the provisions of paragraph 26 hereof. The Purchaser hereby irrevocably consents to a court order removing such notice of this Agreement, any caution, or any other document or instrument whatsoever from title to the Property, Unit or the Condominium and the Purchaser agrees to pay all of the Vendor's costs and expenses in obtaining such order (including the Vendor's Solicitor's fees on a full indemnity basis).
17. The Purchaser covenants not to list for sale or lease, advertise for sale or lease, sell or lease, nor in any way assign his or her interest under this Agreement, or the Purchaser's rights and interests hereunder or in the Unit, nor directly or indirectly permit any third party to list or advertise the Unit for sale or lease, at any time until after the Title Transfer Date, without the prior written consent of the Vendor, which consent may be arbitrarily withheld. The Purchaser acknowledges and agrees that once a breach of the preceding covenant occurs, such breach is or shall be incapable of rectification, and accordingly the Purchaser acknowledges, and agrees that in the event of such breach, the Vendor shall have the unilateral right and option of terminating this Agreement and the Occupancy License, effective upon delivery of notice of termination to the Purchaser or the Purchaser's solicitor, whereupon the provisions of this Agreement dealing with the consequence of termination by reason of the Purchaser's default, shall apply. The Purchaser shall be entitled to direct that title to the Unit be taken in the name of his or her spouse, or a member of his or her immediate family only, and shall not be permitted to direct title to any other third parties.
18. The Purchaser acknowledges that the Vendor is (or may in the future be) processing and/or completing one or more rezoning or minor variance applications with respect to the Lands (and/or the lands adjacent thereto or in the neighbouring vicinity thereof), as a well as a site plan approval/development application/draft plan of condominium approval with respect to the Lands, in order to permit the development and construction of the Condominium thereon. The Purchaser acknowledges that during the rezoning, minor variance, site plan and/or draft plan of condominium approval process, the footprint or siting of the condominium building may shift from that originally proposed or intended, the overall height of the condominium building (and the number of levels/floors, and/or the number of dwelling units comprising the Condominium) may vary, and the location of the Condominium's proposed amenities may likewise be altered, without adversely affecting the floor plan layout, design and size of the interior of the Unit, and the Purchaser hereby expressly agrees to complete this transaction notwithstanding the foregoing, without any abatement in the Purchase Price, and without any entitlement to a claim for damages or other compensation whatsoever. The Purchaser further covenants and agrees that it shall not oppose the aforementioned zoning, minor variance and site plan/development applications, nor any other applications ancillary thereto, including without limitation, any application submitted or pursued by or on behalf of the Vendor to lawfully permit the development and registration of the Condominium, or to obtain an increase in the density coverage or the dwelling unit count (or yield) thereof, or for any other lawful purpose whatsoever, and the Purchaser expressly acknowledges and agrees that this covenant may be pleaded as an estoppel or bar to any opposition or objection raised by the Purchaser thereto.



19. The Purchaser covenants and agrees that he/she shall not interfere with the completion of other units and the common elements by the Vendor. Until the Condominium is completed and all units sold and transferred the Vendor may make such use of the Condominium as may facilitate the completion of the Condominium and sale of all the units, including, but not limited to the maintenance of a sales/rental/administration/construction office(s) and model units, and the display of signs located on the Property.

**Termination without Default**

20. In the event this Agreement is terminated through no fault of the Purchaser, all deposit monies paid by the Purchaser towards the Purchase Price, together with any interest required by law to be paid, shall be returned to the Purchaser; provided however, that the Vendor shall not be obligated to return any monies paid by the Purchaser as an Occupancy Fee. The Vendor shall be entitled to require the Purchaser to execute a release of any surety, lender or any other third party requested by the Vendor in its discretion prior to the return of such monies. In no event shall the Vendor or its agents be liable for any damages or costs whatsoever and without limiting the generality of the foregoing, for any loss of bargain, for any relocating costs, or for any professional or other fees paid in relation to this transaction. This provision may be pleaded by the Vendor as a complete defence to any such claim.

**Tarion Warranty Corporation**

21. The Vendor represents and warrants to the Purchaser that the Vendor is a registered vendor/builder with the TWC. The Purchaser acknowledges and agrees that any warranties of workmanship or materials, in respect of any aspect of the construction of the Condominium including the Unit, whether implied by this Agreement or at law or in equity or by any statute or otherwise, shall be limited to only those warranties deemed to be given by the Vendor under the ONHWPA and shall extend only for the time period and in respect of those items as stated in the ONHWPA, it being understood and agreed that there is no representation, warranty, guarantee, collateral agreement, or condition precedent to, concurrent with or in any way affecting this Agreement, the Condominium or the Unit, other than as expressed herein. The Purchaser hereby irrevocably appoints the Vendor his/her agent to complete and execute the TWC Certificate of Deposit and any excess condominium deposit insurance documentation in this regard, as required, both on its own behalf and on behalf of the Purchaser.

**Right of Entry**

22. Notwithstanding the Purchaser occupying the Unit on the Occupancy Date or the closing of this transaction and the delivery of title to the Unit to the Purchaser, as applicable, the Vendor or any person authorized by it shall be entitled at all reasonable times and upon reasonable prior notice to the Purchaser to enter the Unit and the common elements in order to make inspections or to do any work or replace therein or thereon which may be deemed necessary by the Vendor in connection with the Unit or the common elements and such right shall be in addition to any rights and easements created under the Act. A right of entry in favour of the Vendor for a period not exceeding five (5) years similar to the foregoing may be included in the Transfer/Deed provided on the Title Transfer Date and acknowledged by the Purchaser at the Vendor's sole discretion.

**Occupancy**

23. (a) The Unit shall be deemed to be substantially completed when the interior work has been finished to the minimum standards allowed by the Municipality so that the Unit may be lawfully occupied notwithstanding that there remains other work within the Unit and/or the common elements to be completed. The Purchaser shall not occupy the Unit until the Municipality has permitted same or consented thereto, if such consent is required and the Occupancy Date shall be postponed until such required consent is given. The Purchaser shall not require the Vendor to provide or produce an occupancy permit, certificate or authorization from the Municipality other than the documentation required by paragraph 8 of the Tarion Addendum. Provided that the Vendor complies with paragraph 8 of the Tarion Addendum, the Purchaser acknowledges that the failure to complete the common elements before the Occupancy Date shall not be deemed to be failure to complete the Unit, and the Purchaser agrees to complete this transaction notwithstanding any claim submitted to the Vendor and/or to the TWC in respect of apparent deficiencies or incomplete work provided, always, that such incomplete work does not prevent occupancy of the Unit as, otherwise, permitted by the Municipality.
- (b) If the Unit is substantially complete and fit for occupancy on the Occupancy Date, as provided for in subparagraph (a) above, but the Creating Documents have not been registered, (or in the event the Condominium is registered prior to the Occupancy Date and closing documentation has yet to be prepared), the Purchaser shall pay to the Vendor a further amount on account of the Purchase Price specified in paragraph 1(b) hereof without adjustment save for any pro-rated portion of the Occupancy Fee described and calculated in Schedule "C", and the Purchaser shall occupy the Unit on the Occupancy Date pursuant to the Occupancy Licence attached hereto as Schedule "C".

**Inspection**

24. (a) The Purchaser or the Purchaser's designate as hereinafter provided agrees to meet the Vendor's representative at the date and time designated by the Vendor, prior to the Occupancy Date, to conduct a pre-delivery inspection of the Unit (the "PDI") and to list all items remaining incomplete at the time of such inspection together with all mutually agreed deficiencies with respect to the Unit, on the TWC Certificate of Completion and Possession (the "CCP") and the PDI Form, in the forms prescribed from time to time by, and required to be completed pursuant to the provisions of the ONHWPA. The said CCP and PDI Forms shall be executed by both the Purchaser or the Purchaser's designate and the Vendor's representative at the PDI and shall constitute the Vendor's only undertaking with respect to incomplete or deficient work and the Purchaser shall not require any further undertaking of the Vendor to complete any outstanding items. In the event that the Vendor performs any additional work to the Unit in its discretion, the Vendor shall not be deemed to have waived the provision of this paragraph or otherwise enlarged its obligations hereunder.
- (b) The Purchaser acknowledges that the Homeowner Information Package as defined in TWC Bulletin 42 (the "HIP") is available from TWC and that the Vendor further agrees to provide the HIP to the Purchaser or the Purchaser's designate, at or before the PDI. The Purchaser or the Purchaser's designate agrees to execute and provide to the Vendor the Confirmation of Receipt of the HIP forthwith upon receipt of the HIP.

- (c) The Purchaser shall be entitled to send a designate to conduct the PDI in the Purchaser's place or attend with their designate, provided the Purchaser first provides to the Vendor a written authority appointing such designate for PDI prior to the PDI. If the Purchaser appoints a designate, the Purchaser acknowledges and agrees that the Purchaser shall be bound by all of the documentation executed by the designate to the same degree and with the force and effect as if executed by the Purchaser directly.
- (d) In the event the Purchaser and/or the Purchaser's designate fails to attend the PDI or fails to execute the CCP and PDI Forms at the conclusion of the PDI, the Vendor may declare the Purchaser to be in default under this Agreement and may exercise any or all of its remedies set forth in this Agreement of Purchase and Sale and/or at law. Alternatively, the Vendor may, at its option, complete the within transaction but not provide the keys to the Unit to the Purchaser until the CCP and PDI Forms have been executed by the Purchaser and/or its designate or complete the within transaction and complete the CCP and PDI Forms on behalf of the Purchaser and/or the Purchaser's designate and the Purchaser hereby irrevocably appoints the Vendor the Purchaser's attorney and/or agent and/or designate to complete the CCP and PDI Forms on the Purchaser's behalf and the Purchaser shall be bound as if the Purchaser or the Purchaser's designate had executed the CCP and PDI Forms.
- (e) In the event the Purchaser and/or the Purchaser's designate fails to execute the Confirmation of Receipt of the HIP forthwith upon receipt thereof, the Vendor may declare the Purchaser to be in default under this Agreement and may exercise any or all of its remedies set forth in this Agreement of Purchase and Sale and/or at law.

**Purchaser's Default**

25. (a) In the event that the Purchaser is in default with respect to any of his or her obligations contained in this Agreement (other than paragraph 2(d) hereof) or in the Occupancy License on or before the Title Transfer Date and fails to remedy such default forthwith, if such default is a monetary default and/or pertains to the execution and delivery of documentation required to be given to the Vendor on the Occupancy Date or the Title Transfer Date, or within five (5) days of the Purchaser being so notified in writing with respect to any other non-monetary default, then the Vendor, in addition to (and without prejudice to) any other rights or remedies available to the Vendor (at law or in equity) may, at its sole option, unilaterally suspend all of the Purchaser's rights, benefits and privileges contained herein (including without limitation, the right to make colour and finish selections with respect to the Unit as hereinbefore provided or contemplated), and/or unilaterally declare this Agreement and the Occupancy License to be terminated and of no further force or effect. All monies paid hereunder (including the deposit monies paid or agreed to be paid by the Purchaser pursuant to this Agreement which sums shall be accelerated on demand of the Vendor), together with any interest earned thereon and monies paid or payable for extras or upgrades or changes ordered by the Purchaser, whether or not installed in the Dwelling, shall be forfeited to the Vendor. The Purchaser agrees that the forfeiture of the aforesaid monies shall not be a penalty and it shall not be necessary for the Vendor to prove it suffered any damages in order for the Vendor to be able to retain the aforesaid monies. The Vendor shall in such event still be entitled to claim damages from the Purchaser in addition to any monies forfeited to the Vendor. The aforesaid retention of monies is in addition to (and without prejudice to) any other rights or remedies available to the Vendor at law or in equity. In the event of the termination of this Agreement and/or the Occupancy License by reason of the Purchaser's default as aforesaid, then the Purchaser shall be obliged to forthwith vacate the Unit (or cause same to be forthwith vacated) if same has been occupied (and shall leave the Unit in a clean condition, without any physical or cosmetic damages thereto, and clear of all garbage, debris and any furnishings and/or belongings of the Purchaser), and shall execute such releases and any other documents or assurances as the Vendor may require, in order to confirm that the Purchaser does not have (and the Purchaser hereby covenants and agrees that he/she does not have) any legal, equitable or proprietary interest whatsoever in the Unit and/or the Property (or any portion thereof) prior to the completion of this transaction and the payment of the entire Purchase Price to the Vendor or the Vendor's solicitors as hereinbefore provided, and in the event the Purchaser fails or refuses to execute same, the Purchaser hereby appoints the Vendor to be his or her lawful attorney in order to execute such releases, documents and assurances in the Purchaser's name, place and stead, and in accordance with the provisions of the *Powers of Attorney Act*, R.S.O. 1990, as amended, the Purchaser hereby declares that this power of attorney may be exercised by the Vendor during any subsequent legal incapacity on the part of the Purchaser. In the event the Vendor's Solicitors or an Escrow Agent is/are holding any of the deposits in trust pursuant to this Agreement, then in the event of default as aforesaid, the Purchaser hereby releases the said solicitors or Escrow Agent from any obligation to hold the deposit monies, in trust, and shall not make any claim whatsoever against the said solicitors or Escrow Agent and the Purchaser hereby irrevocably directs and authorizes the said solicitors or Escrow Agent to deliver the said deposit monies and accrued interest, if any, to the Vendor.
- (b) Notwithstanding subparagraph (a) above, the Purchaser acknowledges and agrees that if any amount, payment and/or adjustment which are due and payable by the Purchaser to the Vendor pursuant to this Agreement are not made and/or paid on the date due, but are subsequently accepted by the Vendor, notwithstanding the Purchaser's default, then such amount, payment and/or adjustment shall, until paid, bear interest at the rate equal to eight (8%) percent per annum above the bank rate as defined in subsection 19(2) of O. Reg. 48/01 to the Act at the date of default.

**Common Elements**

26. The Purchaser acknowledges that the Condominium will be constructed to Ontario Building Code requirements at the time of issuance of the building permit. The Purchaser covenants and agrees the Purchaser shall have no claims against the Vendor for any equal, higher or better standards of workmanship or materials. The Purchaser agrees that the foregoing may be pleaded by the Vendor as an estoppel in any action brought by the Purchaser or his/her successors in title against the Vendor. The Vendor may, from time to time, change, vary or modify in its sole discretion or at the instance of any governmental authority or mortgagee, any elevations, building specifications or site plans of any part of the Condominium, to conform with any municipal or architectural requirements related to building codes, official plan or official plan amendments, zoning by-laws, committee of adjustment and/or land division committee decisions, municipal site plan approval or architectural control. Such changes may be to the plans and specifications existing at inception of the Condominium or as they existed at the time the Purchaser entered into this Agreement, or as illustrated on any sales material, including without limitation, brochures, models or otherwise. With respect to any aspect of

construction, finishing or equipment, the Vendor shall have the right, without the Purchaser's consent, to substitute materials, for those described in this Agreement or in the plans or specifications, provided the substituted materials are in the judgment of the Vendor's architect, whose determination shall be final and binding, of equal or better quality. The Purchaser shall have no claim against the Vendor for any such changes, variances or modifications nor shall the Vendor be required to give notice thereof. The Purchaser hereby consents to any such alterations and agrees to complete the sale notwithstanding any such modifications.

Executions

27. The Purchaser agrees to provide to the Vendor's Solicitors on the Occupancy Date a clear and up-to-date Execution Certificate confirming that no executions are filed at the local Land Titles Office against the individual(s) in whose name title to the Unit is being taken.

Risk

28. The Unit shall be and remain at the risk of the Vendor until the Title Transfer Date, subject to the terms of the Occupancy Licence attached hereto as Schedule "C". If any part of the Condominium is damaged before the Creating Documents are registered, the Vendor may in its sole discretion either:

- (a) make such repairs as are necessary to complete this transaction and, if necessary, delay the Occupancy Date in the manner permitted in paragraph 7 of the Taron Addendum;
- (b) terminate this Agreement and return to the Purchaser all deposit monies paid by the Purchaser to the Vendor, with interest payable under law if the damage to the Condominium has frustrated this Agreement at law; or
- (c) apply to a court of competent jurisdiction for an order terminating the Agreement in accordance with the provisions of subsection 79(3) of the Act,

it being understood and agreed that all insurance policies and the proceeds thereof are to be for the benefit of the Vendor alone.

Tender/Termet

29. (a) The parties waive personal tender and agree that tender, in the absence of any other mutually acceptable arrangement and subject to the provisions of paragraph 30 of this Agreement shall be validly made by the Vendor upon the Purchaser, by a representative of the Vendor attending at the offices of Harris, Sheaffer, LLP at 12:00 noon on the Title Transfer Date or the Occupancy Date as the case may be and remaining there until 5:00 p.m. and is ready, willing and able to complete the transaction. The Purchaser agrees that keys may be released to the Purchaser as the construction site or sales office on the Occupancy Date or the Title Transfer Date, as applicable. The Vendor's advice that the keys are available shall be valid tender of possession of the Property to the Purchaser. In the event the Purchaser or his or her solicitor fails to appear or appears and fails to close, such attendance by the Vendor's representative (which includes the Vendor's Solicitors) shall be deemed satisfactory evidence that the Vendor is ready, willing and able to complete the sale at such time. Payment shall be tendered by certified cheque drawn on any Canadian chartered bank; and
- (b) It is further provided that, notwithstanding subparagraph 29 (a) hereof, in the event the Purchaser or his or her solicitor advise the Vendor or its Solicitors, on or before the Occupancy Date or Title Transfer Date, as applicable, that the Purchaser is unable or unwilling to complete the purchase or take occupancy, the Vendor is relieved of any obligation to make any formal tender upon the Purchaser or his or her solicitor and may exercise forthwith any and all of its right and remedies provided for in this Agreement and at law.
30. As the electronic registration system (hereinafter referred to as the "Teraview Electronic Registration System" or ("TERS") is operative in the applicable Land Titles Office in which the Property is registered, then at the option of the Vendor's solicitor, the following provisions shall prevail:
- (a) The Purchaser shall be obliged to retain a solicitor, who is both an authorized TERS user and in good standing with the Law Society of Upper Canada to represent the Purchaser in connection with the completion of the transaction. The Purchaser shall authorize such solicitor to, at the option of the Vendor's Solicitors, either execute an escrow closing agreement with the Vendor's Solicitor on the standard form recommended by the Law Society of Upper Canada (hereinafter referred to as the "Escrow Document Registration Agreement") establishing the procedures and timing for completing this transaction or to otherwise agree to be bound by the procedures set forth in the Escrow Document Registration Agreement.
  - (b) The delivery and exchange of documents, monies and keys to the Unit and the release thereof to the Vendor and the Purchaser, as the case may be:
    - (i) shall not occur contemporaneously with the registration of the Transfer/Deed (and other registerable documentation); and
    - (ii) shall be governed by the Escrow Document Registration Agreement, pursuant to which the solicitor receiving the documents, keys and/or certified funds will be required to hold same in escrow, and will not be entitled to release same except in strict accordance with the provisions of the Escrow Document Registration Agreement.
  - (c) If the Purchaser's solicitor is unwilling or unable to complete this transaction via TERS, in accordance with the provisions contemplated under the Escrow Document Registration Agreement, then said solicitor (or the authorized agent thereof) shall be obliged to personally attend at the office of the Vendor's solicitor, at such time on the Title Transfer Date as may be directed by the Vendor's solicitor or as mutually agreed upon, in order to complete this transaction via TERS utilizing the computer facilities in the Vendor's solicitor's office, and shall pay a fee as determined by the Vendor's solicitor, acting reasonably for the use of the Vendor's computer facilities.

- (d) The Purchaser expressly acknowledges and agrees that he or she will not be entitled to receive the Transfer/Deed to the Unit for registration until the balance of funds due on closing, in accordance with the statement of adjustments, are either remitted by certified cheque via personal delivery or by electronic funds transfer to the vendor's solicitor (or in such other manner as the latter may direct) prior to the release of the Transfer/Deed for registration.
- (e) Each of the parties hereto agrees that the delivery of any documents not intended for registration on title to the Unit may be delivered to the other party hereto by telefax transmission (or by a similar system reproducing the original or by electronic transmission of electronically signed documents through the Internet), provided that all documents so transmitted have been duly and properly executed by the appropriate parties/signatories thereto which may be by electronic signature. The party transmitting any such document shall also deliver the original of same (unless the document is an electronically signed document pursuant to the *Electronic Commerce Act*) to the recipient party by overnight courier sent the day of closing or within 7 business days of closing, if same has been so requested by the recipient party.
- (f) Notwithstanding anything contained in this agreement to the contrary, it is expressly understood and agreed by the parties hereto that an effective tender shall be deemed to have been validly made by the Vendor upon the Purchaser when the Vendor's solicitor has:
  - (i) delivered all closing documents and/or funds to the Purchaser's solicitor in accordance with the provisions of the Escrow Document Registration Agreement and keys are made available for the Purchaser to pick up at the Vendor's sales of customer service office;
  - (ii) advised the Purchaser's solicitor, in writing, that the Vendor is ready, willing and able to complete the transaction in accordance with the terms and provisions of this Agreement; and
  - (iii) has completed all steps required by TERS in order to complete this transaction that can be performed or undertaken by the Vendor's solicitor without the cooperation or participation of the Purchaser's solicitor, and specifically when the "completeness signatory" for the transfer/deed has been electronically "signed" by the Vendor's solicitor;

without the necessity of personally attending upon the Purchaser or the Purchaser's solicitor with the aforementioned documents, keys and/or funds, and without any requirement to have an independent witness evidencing the foregoing.

#### General

- 31. The Vendor shall provide a statutory declaration on the Title Transfer Date that it is not a non-resident of Canada within the meaning of the ITA.
- 32. The Vendor and Purchaser agree to pay the costs of registration of their own documents and any tax in connection therewith.
- 33. The Vendor and the Purchaser agree that there is no representation, warranty, collateral agreement or condition affecting this Agreement or the Property or supported hereby other than as expressed herein in writing.
- 34. This Offer and its acceptance is to be read with all changes of gender or number required by the context and the terms, provisions and conditions hereof shall be for the benefit of and be binding upon the Vendor and the Purchaser, and as the context of this Agreement permits, their respective heirs, estate trustees, successors and permitted assigns.
- 35. The Purchaser acknowledges that the suite area of the Unit, as may be represented or referred to by the Vendor or any sales agent, or which appear in any sales material is approximate only, and is generally measured to the outside of all exterior, corridor and stairwell walls, and to the centre line of all party walls separating one unit from another. NOTE: For more information on the method of calculating the floor area of any unit, reference should be made to Builder Bulletin No. 22 published by the TWC. Actual useable floor space may (therefore) vary from any stated or represented floor area or gross floor area, and the extent of the actual or useable living space within the confines of the Unit may vary from any represented square footage or floor area measurement(s) made by or on behalf of the Vendor. In addition, the Purchaser is advised that the floor area measurements are generally calculated based on the middle floor of the Condominium building for each suite type, such that units on lower floors may have less floor space due to thicker structural members, mechanical rooms, etc., while units on higher floors may have more floor space. Accordingly, the Purchaser hereby confirms and agrees that all details and dimensions of the Unit purchased hereunder are approximate only, and that the Purchase Price shall not be subject to any adjustment or claim for compensation whatsoever, whether based upon the ultimate square footage of the Unit, or the actual or useable living space within the confines of the Unit or otherwise. The Purchaser further acknowledges that the ceiling height of the Unit is measured from the upper surface of the concrete floor slab (or subfloor) to the underside surface of the concrete ceiling slab (or joists). However, where ceiling bulkheads are installed within the Unit, and/or where dropped ceilings are required, then the ceiling height of the Unit will be less than that represented, and the Purchaser shall correspondingly be obliged to accept the same without any abatement or claim for compensation whatsoever.
- 36. This Agreement shall be governed by and construed in accordance with the laws of the Province of Ontario.
- 37. The headings of this Agreement form no part hereof and are inserted for convenience of reference only.
- 38. Each of the provisions of this Agreement shall be deemed independent and severable and the invalidity or unenforceability in whole or in part of any one or more of such provisions shall not be deemed to impair or affect in any manner the validity, enforceability or effect of the remainder of this Agreement, and in such event all the other provisions of this Agreement shall continue in full force and effect as if such invalid provision had never been included herein. The Purchaser and the Vendor acknowledge and agree that this Agreement and all amendments and addenda thereto shall constitute an agreement made under seal.
- 39. (a) If any documents required to be executed and delivered by the Purchaser to the Vendor are, in fact, executed by a third party appointed as the attorney for the Purchaser, then the power of attorney appointing such person must be registered in the Land Titles office where the Lands are registered, and a duplicate registered

copy thereof (together with a statutory declaration sworn by the Purchaser's solicitor unequivocally confirming, without any qualification whatsoever, that said power of attorney has not been revoked) shall be delivered to the Vendor along with such documents.

- (b) Where the Purchaser is a corporation, or where the Purchaser is buying in trust for another person or corporation for a disclosed or undisclosed beneficiary or principal (including, without limitation, a corporation to be incorporated), the execution of this Agreement by the principal or principals of such corporation, or by the person named as the Purchaser in trust as the case may be, shall be deemed and construed to constitute the personal indemnity of such person or persons so signing with respect to the obligations of the Purchaser herein and shall be fully liable to the Vendor for the Purchaser's obligations under this Agreement and may not plead such agency, trust relationship or any other relationships as a defence to such liability.

#### Notice

40. (a) Any notice required to be delivered under the provisions of the Tarion Addendum shall be delivered in the manner required by paragraph 14 of the Tarion Addendum.
- (b) Any other notice given pursuant to the terms of this Agreement shall be deemed to have been properly given if it is in writing and is delivered by hand, ordinary prepaid post, facsimile transmission or electronic mail to the attention of the Purchaser or to the Purchaser's solicitor to their respective addresses indicated herein or to the address of the Unit after the Occupancy Date and to the Vendor at 8791 Woodbine Avenue, Suite 100, Markham, Ontario, L3R 0P4, or to the Vendor's Solicitors at the address indicated in this Agreement or such other address as may from time to time be given by notice in accordance with the foregoing. Such notice shall be deemed to have been received on the day it was delivered by hand, by electronic mail or by facsimile transmission and upon the third day following posting, excluding Saturdays, Sundays and statutory holidays. This agreement or any amendment or addendum thereto may, at the Vendor's option, be properly delivered if it delivered by facsimile transmission or if a copy of same is computer scanned and forwarded by electronic mail to the other party.

#### Material Change

41. The Purchaser acknowledges and agrees that the Vendor may, from time to time in its sole discretion, due to site conditions or constraints, or for marketing considerations, or for any other legitimate reason, including without limitation any request or requirement of any of the governmental authorities or any request or requirement of the Vendor's architect or other design consultants:
- (a) change the Property's municipal address or numbering of the Unit (in terms of the unit number and/or level number ascribed to any one or more of the units comprising the Unit);
- (b) change, vary or modify the plans and specifications pertaining to the Unit or the Condominium, or any portion thereof (including architectural, structural, engineering, landscaping, grading, mechanical, site servicing and/or other plans and specifications) from the plans and specifications existing at the inception of the project, or existing at the time that the Purchaser has entered into this Agreement, or as same may be illustrated in any sales brochure(s), model(s) in the sales office or otherwise, including without limitation, making any change to the total number of dwelling, parking, locker and/or other ancillary units intended to be created within the Condominium, and/or any change to the total number of levels or floors within the Condominium, as well as any changes or alterations to the design, style, size and/or configuration of any dwelling or other ancillary units within the Condominium;
- (c) change, vary, or modify the number, size and location of any windows, column(s) and/or bulkhead(s) within or adjacent to (or comprising part of) the Unit, from the number, size and/or location of same as displayed or illustrated in any sales brochure(s), model(s) or floor plan(s) previously delivered or shown to the Purchaser, including the insertion or placement of any window(s), column(s) and/or bulkhead(s) in one or more locations within the Unit which have not been shown or illustrated in any sales brochure(s), model(s) or floor plan(s) previously delivered or shown to the Purchaser (regardless of the extent or impact thereof), as well as the removal of any window(s), column(s) and/or bulkhead(s) from any location(s) previously shown or illustrated in any sales brochure(s), model(s) in the sales office or otherwise; and/or
- (d) change the layout of the Unit such that same is a mirror image of the layout shown to the Purchaser (or a mirror image of the layout illustrated in any sales brochure or other marketing material(s) delivered to the Purchaser);

and that the Purchaser shall have absolutely no claim or cause of action whatsoever against the Vendor or its sales representatives (whether based or founded in contract, tort or in equity) for any such changes, deletions, alterations or modifications, nor shall the Purchaser be entitled to any abatement or reduction in the Purchase Price whatsoever as a consequence thereof, nor any notice thereof (unless any such change, deletion, alteration or modification to the said plans and specifications is material in nature (as defined by the Act) and significantly affects the fundamental character, use or value of the Unit and/or the Condominium, in which case the Vendor shall be obliged to notify the Purchaser in writing of such change, deletion, alteration or modification as soon as reasonably possible after the Vendor proposes to implement same, or otherwise becomes aware of same), and where any such change, deletion, alteration or modification to the said plans and specifications is material in nature, then the Purchaser's only recourse and remedy shall be the termination of this Agreement prior to the Title Transfer Date, (and specifically within 10 days after the Purchaser is notified or otherwise becomes aware of such material change), and the return of the Purchaser's deposit monies, together with interest accrued thereon at the rate prescribed by the Act.

#### Cause of Action/Assignment

42. (a) The Purchaser acknowledges and agrees that notwithstanding any rights which he or she might otherwise have at law or in equity arising out of this Agreement, the Purchaser shall not assert any of such rights, nor have any claim or cause of action whatsoever as a result of any matter or thing arising under or in connection with this Agreement (whether based or founded in contract law, tort law or in equity, and whether for

innocent misrepresentation, negligent misrepresentation, breach of contract, breach of fiduciary duty, breach of constructive trust or otherwise), against any person, firm, corporation or other legal entity, other than the person, firm, corporation or legal entity specifically named or defined as the Vendor herein, even though the Vendor may be (or may ultimately be found or adjudged to be) a nominee or agent of another person, firm, corporation or other legal entity, or a trustee for and on behalf of another person, firm, corporation or other legal entity, and this acknowledgment and agreement may be pleaded as an estoppel and bar against the Purchaser in any action, suit, application or proceeding brought by or on behalf of the Purchaser to assert any of such rights, claims or causes of action against any such third parties. Furthermore, the Purchaser and the Vendor acknowledge that this Agreement shall be deemed to be a contract under seal.

- (b) At any time prior to the Title Transfer Date, the Vendor shall be permitted to assign this Agreement (and its rights, benefits and interests hereunder) to any person, firm, partnership or corporation registered as a vendor pursuant to the ONHWSA and upon any such assignee assuming all obligations under this Agreement and notifying the Purchaser or the Purchaser's solicitor of such assignment, the Vendor named herein shall be automatically released from all obligations and liabilities to the Purchaser arising from this Agreement, and said assignee shall be deemed for all purposes to be the vendor herein as if it had been an original party to this Agreement, in the place and stead of the Vendor.

Non-Merger:

43. The covenants and agreements of each of the parties hereto shall not merge on the Title Transfer Date, but shall remain in full force and effect according to their respective terms, until all outstanding obligations of each of the parties hereto have been duly performed or fulfilled in accordance with the provisions of this Agreement. No further written assurances evidencing or confirming the non-merger of the covenants of either of the parties hereto shall be required or requested by or on behalf of either party hereto.

Notice/Warning Provisions

44. The Purchaser acknowledges that it is anticipated by the Vendor that in connection with the Vendor's application to the appropriate governmental authorities for draft plan of condominium approval certain requirements may be imposed upon the Vendor by various governmental authorities. These requirements (the "Requirements") usually relate to warning provisions to be given to Purchasers in connection with environmental or other concerns (such as warnings relating to noise levels, the proximity of the Condominium to major street, garbage storage and pickup, school transportation, and similar matters). Accordingly, the Purchaser covenants and agrees that (1) on either the Occupancy Date or Title Transfer Date, as determined by the Vendor, the Purchaser shall execute any and all documents required by the Vendor acknowledging, inter alia, that the Purchaser is aware of the Requirements, and (2) if the Vendor is required to incorporate the Requirements into the final Condominium Documents the Purchaser shall accept the same, without in any way affecting this transaction. Notwithstanding the generality of the foregoing, the Purchaser agrees to be bound by the warnings set forth in Schedule "D" hereto.

Purchaser's Consent to the Collection and Limited Use of Personal Information

45. The Purchaser hereby consents to the Vendor's collection, use and disclosure of the Purchaser's personal information for the purpose of enabling the Vendor to proceed with the Purchaser's purchase of the Unit, completion of this transaction, and for post-closing and after-sales customer care purposes. Such personal information includes the Purchaser's name, home address, e-mail address, telefax/telephone number, age, date of birth, marital and residency status, social insurance number (only with respect to subparagraph (b) below), financial information, desired suite design(s), and colour/finish selections. In particular, but without limiting the foregoing, the Vendor may disclose such personal information to:
- (a) Any relevant governmental authorities or agencies, including without limitation, the Land Titles Office (in which the Condominium is registered), the Ministry of Finance for the Province of Ontario (i.e. with respect to Land Transfer Tax), and the Canada Revenue Agency (i.e. with respect to GST);
  - (b) Canada Revenue Agency, to whose attention the T-5 interest income tax information return and/or the NR4 non-resident withholding tax information return is submitted (where applicable), which will contain or refer to the Purchaser's social insurance number or business registration number (as the case may be), as required by Regulation 201(1)(b)(ii) of the ITA, as amended;
  - (c) The Condominium for the purposes of facilitating the completion of the Condominium's voting, leasing and/or other relevant records and to the Condominium's property manager for the purposes of facilitating the issuance of notices, the collection of common expenses and/or implementing other condominium management/administration functions;
  - (d) any companies or legal entities that are associated with, related to or affiliated with the Vendor, other future condominium declarants that are likewise associated with, related to or affiliated with the Vendor (or with the Vendor's parent/holding company) and are developing one or more other condominium projects or communities that may be of interest to the Purchaser or members of the Purchaser's family, for the limited purposes of marketing, advertising and/or selling various products and/or services to the Purchaser and/or members of the Purchaser's family;
  - (e) any financial institution(s) providing (or wishing to provide) mortgage financing, banking and/or other financial or related services to the Purchaser and/or members of the Purchaser's family, with respect to the Unit, including without limitation, the Vendor's construction lender(s), the quantity surveyor monitoring the Project and its costs, the Vendor's designated construction lender(s), the Tarion Warranty Corporation and/or any warranty bond provider and/or excess condominium deposit insurer, required in connection with the development and/or construction financing of the Condominium and/or the financing of the Purchaser's acquisition of the Property from the Vendor;
  - (f) any insurance companies of the Vendor providing (or wishing to provide) insurance coverage with respect to the Property (or any portion thereof) and/or the common elements of the Condominium, and any title insurance companies providing (or wishing to provide) title insurance to the Purchaser or the Purchaser's mortgage lender(s) in connection with the completion of this transaction;

- (g) any trades/suppliers or sub-trades/suppliers, who have been retained by or on behalf of the Vendor (or who are otherwise dealing with the Vendor) to facilitate the completion and finishing of the Unit and the installation of any extras or upgrades ordered or requested by the Purchaser;
- (h) one or more providers of cable television, telephone, telecommunication, security alarm systems, hydro-electricity, chilled water/hot water, gas and/or other similar or related services to the Property (or any portion thereof ) and/or the Condominium (collectively, the "Utilities"), unless the Purchaser gives the Vendor prior notice in writing not to disclose the Purchaser's personal information to one or more of the Utilities;
- (i) one or more third party data processing companies which handle or process marketing campaigns on behalf of the Vendor or other companies that are associated with, related to or affiliated with the Vendor, and who may send (by e-mail or other means) promotional literature/brochures about new condominiums and/or related services to the Purchaser and/or members of the Purchaser's family, unless the Purchaser gives the Vendor prior notice in writing not to disclose the Purchaser's personal information to said third party data processing companies;
- (j) the Vendor's solicitors, to facilitate the interim occupancy and/or final closing of this transaction, including the closing by electronic means via the Teraview Electronic Registration System, and which may (in turn) involve the disclosure of such personal information to an internet application service provider for distribution of documentation;
- (k) any person, where the Purchaser further consents to such disclosure or disclosures required by law.

Any questions or concerns of the Purchaser with respect to the collection, use or disclosure of his or her personal information may be delivered to the Vendor at the address set out in the Tarion Addendum, Attention: Privacy Officer.

M:\081080917\Masters\Agreement of Purchase and Sale (October 18 09).DOC



SCHEDULE "A" TO THE AGREEMENT OF PURCHASE AND SALE

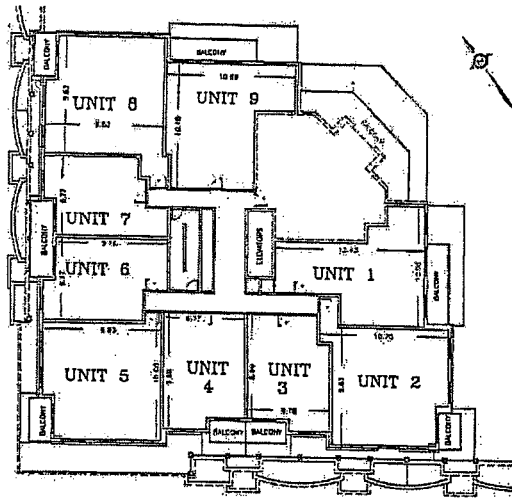

UNITS 1 to 9 (inclusive),  
LEVEL 4  
(NOT TO SCALE)

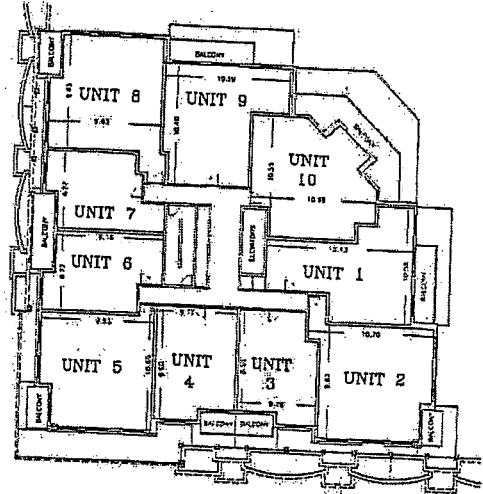
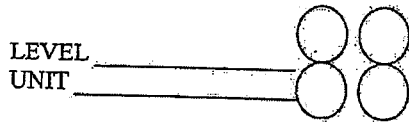

UNITS 1 to 10 (inclusive),  
LEVELS 5 to 13 (inclusive)  
(NOT TO SCALE)

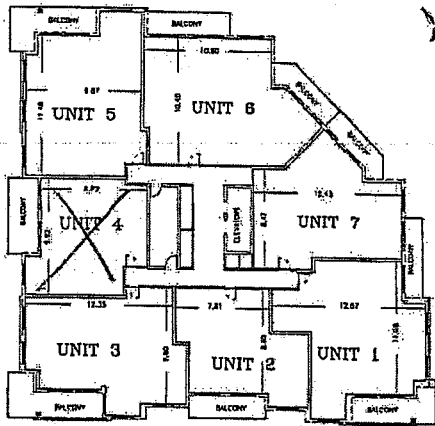
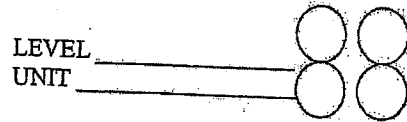

UNITS 1 to 7 (inclusive),  
LEVELS 14 to 17 (inclusive)  
(NOT TO SCALE)

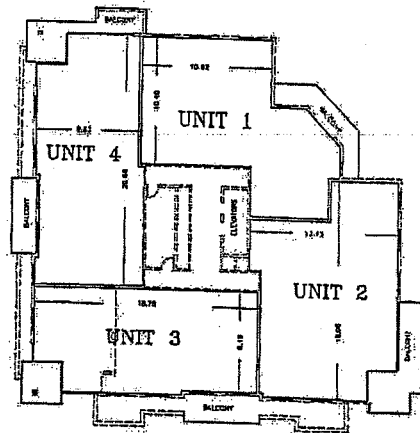
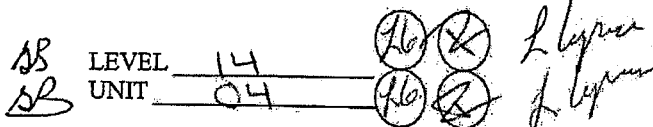

UNITS 1 to 4 (inclusive),  
LEVELS 18 and 19  
(NOT TO SCALE)

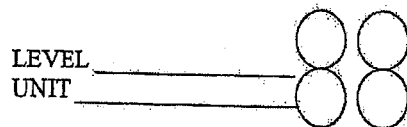

## SCHEDULE "B" TO THE AGREEMENT OF PURCHASE AND SALE

### FEATURES AND FINISHES – TOWER UNITS

#### The following are included in the Purchase Price:

- Engineered hardwood flooring in living, dining and den areas
- 40oz carpet with foam under pad in bedroom(s)
- Ceramic tile in kitchen, laundry, bathroom(s), and entrance areas
- Bi-fold doors for all closet/storage areas, painted white
- Digital Thermostat(s) for individual climate control of suite
- Smooth finished ceilings
- Contemporary trim package including nominal 4" painted base, lever passage and privacy sets
- Interior walls are primed and then painted with two coats of off-white, latex paint (bathroom(s), and all woodwork and trim painted with durable white semi-gloss paint). Paints have low levels of volatile organic compounds (VOCs).
- 6'8" foot interior doors with lever hardware, complete with contemporary casings
- 7 foot solid wood entry door with security peeper, lever set hardware and suite number on the escutcheon plate for floors 4-13. 8 foot solid wood entry door with security peeper, lever set hardware and suite number on the escutcheon plate for floors 14-19.
- Balcony and Terrace access via sliding patio door(s)
- Balcony to have one exterior electrical receptacle.
- Thermally broken aluminum window frames with, double pane, sealed glazed units, with designated operable windows.
- Where ceiling bulkheads are installed, the ceiling height will be less than the nominal 9 feet. Where dropped ceilings are required, (in areas such as foyers, closets, kitchens, dining rooms, bathrooms, laundry rooms and hallways), the ceiling height will also be less than the nominal 9 feet.

#### **KITCHENS**

- Stainless steel brand name Energy Star ® refrigerator and dishwasher
- Stainless steel brand name electric range, combination microwave/hood vent,
- Kitchen cabinetry with one bank of drawers, pantry per suite design. Cabinets complete with contemporary handles.

- Granite kitchen countertop with polished square edge and stainless steel under mounted double sink.
- Single lever kitchen faucet, complete with pull out spray.
- 4" granite backsplash

#### **BATHROOMS**

- White bathroom fixtures throughout.
- Cultured marble vanity with integrated basin and single lever faucet for the bathroom(s)
- Vanity mirror in clear finish
- 5' acrylic soaker tub with single lever faucet.
- Ceramic tiles in tub area to ceiling height
- Temperature controlled shower faucet.
- Low-flow shower head(s).
- Ceramic tile flooring
- Low consumption toilet(s).

#### **LAUNDRY**

- Brand name stackable washer & dryer combination unit
- Heavy-duty wiring and receptacle for dryer.
- Dryer vented to exterior.

#### **SAFETY and SECURITY**

- Heat detector(s) connected to fire annunciation panel.
- Hard wired smoke alarm(s).

#### **ELECTRICAL SERVICE and FIXTURES**

- Individual electrical power service, separately metered
- Decora series receptacles and switches throughout.
- Light fixtures in foyer, hallway(s), kitchen, breakfast area, and den.
- Capped ceiling light outlet in dining room.

#### **COMMUNICATIONS**

- Pre-wired cable outlet in living room, bedroom(s), den and kitchen
- Pre-wired telephone outlet in living room, bedroom(s), den and kitchen.

- N.B. Subject to paragraph 4 of the Agreement of Purchase and Sale attached hereto, the Vendor shall have the right to substitute other products and materials for those listed in this Schedule or provided for in the plans and specifications provided that the substituted products and materials are of a quality equal to, or better than, the products and materials so listed or so provided.
1. Marble and wood are subject to natural variations in colour and grain. Ceramic tile and broadloom are subject to pattern, shade and colour variations.
  2. If the Unit is at a stage of construction which will enable the Vendor to permit the Purchaser to make colour and material choices from the Vendor's standard selections, then the Purchaser shall have until the Vendor's date designated by the Vendor (of which the Purchaser shall be given at least seven (7) days prior to notice) to properly complete the Vendor's colour and material selection form. If the Purchaser fails to do so within such time period, the Vendor may irrevocably exercise all of the Purchaser's rights to colour and material selections hereunder and such selections shall be binding upon the Purchaser. No changes whatsoever shall be permitted in colours or materials so selected by the Vendor, except that the Vendor shall have the right to substitute other materials and items for those provided in this Schedule provided that such materials and items are of equal quality to or better than the materials and items set out herein.
  3. The Purchaser acknowledges that there shall be no reduction in the price or credit for any standard feature listed herein which is omitted at the Purchaser's request.
  4. References to model types or model numbers refer to current manufacturer's models. If these types or models shall change, the Vendor shall provide an equivalent model.
  5. All dimensions, if any, are approximate.
  6. All specifications and materials are subject to change without notice.
  7. Pursuant to this Agreement or this Schedule or pursuant to a supplementary agreement or purchase order the Purchaser may have requested the Vendor to construct an additional feature within the Unit which is in the nature of an optional extra (such as, by way of example only, a fireplace); if, as a result of building, construction or site conditions within the Unit or the Building, the Vendor is not able to construct such extra, then the Vendor may, by written notice to the Purchaser, terminate the Vendor's obligation to construct the extra. In such event, the Vendor shall refund to the Purchaser the monies, if any, paid by the Purchaser to the Vendor in respect of such extra, without interest and in all other respects this Agreement shall continue in full force and effect.
  8. Floor and specific features will depend on the Vendor's package as selected.

**SCHEDULE "C" TO AGREEMENT OF PURCHASE AND SALE**

**TERMS OF OCCUPANCY LICENCE**

- C.1 The transfer of title to the Unit shall take place on the Title Transfer Date upon which date, unless otherwise expressly provided for hereunder, the term of this Occupancy Licence shall be terminated.
- C.2 The Purchaser shall pay or have paid to the Vendor, on or before the Occupancy Date, by certified cheque drawn on a Canadian chartered bank the amount set forth in paragraph 1(b) of this Agreement without adjustment. Upon payment of such amount on the Occupancy Date, the Vendor grants to the Purchaser a licence to occupy the Unit from the Occupancy Date.

The Purchaser shall pay to the Vendor the Occupancy Fee calculated as follows:

- (a) the amount of interest payable in respect of the unpaid balance of the Purchase Price at the prescribed rate;
- (b) an amount reasonably estimated by the Vendor on a monthly basis for municipal realty taxes attributable by the Vendor to the Unit; and
- (c) the projected monthly common expense contribution for the Unit;

as an occupancy charge on the first day of each month in advance during Interim Occupancy, no part of which shall be credited as payments on account of the Purchase Price, but which payments shall be a charge for occupancy only. If the Occupancy Date is not the first day of the month, the Purchaser shall pay on the Occupancy Date a pro rata amount for the balance of the month by certified funds. The Purchaser shall deliver to the Vendor on or before the Occupancy Date a series of post-dated cheques as required by the Vendor for payment of the estimated monthly Occupancy Fee. The Occupancy Fee may be recalculated by the Vendor, from time to time based on revised estimates of the items which may be lawfully taken into account in the calculation thereof and the Purchaser shall pay to the Vendor such revised Occupancy Fee following notice from the Vendor. With respect to taxes, the Purchaser agrees that the amount estimated by the Vendor on account of municipal realty taxes attributed to the Unit shall be subject to recalculation based upon the real property tax assessment or reassessment of the Units and/or Condominium, issued by the municipality after the Title Transfer Date and the municipal tax mill rate in effect as at the date such assessment or reassessment is issued. The Occupancy Fee shall thereupon be recalculated by the Vendor and any amount owing by one party to the other shall be paid upon demand.

- C.3 The Purchaser shall be allowed to remain in occupancy of the Unit during Interim Occupancy provided the terms of this Occupancy Licence and the Agreement have been observed and performed by the Purchaser. In the event the Purchaser breaches the terms of occupancy the Vendor in its sole discretion and without limitation of any other rights or remedies provided for in this Agreement or at law may terminate this Agreement and revoke the Occupancy Licence whereupon the Purchaser shall be deemed a trespasser and shall give up vacant possession forthwith. The Vendor may take whatever steps it deems necessary to obtain vacant possession and the Purchaser shall reimburse the Vendor for all costs it may incur.
- C.4 At or prior to the time that the Purchaser takes possession of the Unit, the Purchaser shall execute and deliver to the Vendor any documents, directions, acknowledgments, assumption agreements or any and all other documents required by the Vendor pursuant to this Agreement, in the same manner as if the closing of the transaction was taking place at that time.
- C.5 The Purchaser shall pay the monthly Occupancy Fee during Interim Occupancy and the Vendor shall destroy all unused post-dated Occupancy Fee cheques on or shortly after the Title Transfer Date.
- C.6 The Purchaser agrees to maintain the Unit in a clean and sanitary condition and not to make any alterations, improvements or additions thereto without the prior written approval of the Vendor which may be unreasonably withheld. The Purchaser shall be responsible for all utility, telephone expenses, cable television service, or other charges and expenses billed directly to the occupant of the Unit by the supplier of such services and not the responsibility of the Corporation under the Condominium Documents.
- C.7 The Purchaser's occupancy of the Unit shall be governed by the provisions of the Condominium Documents and the provisions of this Agreement. The Unit may only be occupied and used in accordance with the Condominium Documents and for no other purpose.
- C.8 The Vendor covenants to proceed with all due diligence and dispatch to register the Creating Documents. If the Vendor for any reason whatsoever is unable to register the Creating Documents and therefore is unable to deliver a registrable Transfer/Deed to the Purchaser within twenty-four (24) months after the Occupancy Date, the Purchaser or Vendor shall have the right after such twenty-four (24) month period to give sixty (60) days written notice to the other, of an intention to terminate the Occupancy Licence and this Agreement. If the Vendor and Purchaser consent to termination, the Purchaser shall give up vacant possession and pay the Occupancy Fee to such date, after which this Agreement and Occupancy Licence shall be terminated and all moneys paid to the Vendor on account of the Purchase Price shall be returned to the Purchaser together with interest required by the Act, subject however, to any repair and redecorating expenses of the Vendor necessary to restore the Unit to its original state of occupancy, reasonable wear and tear excepted. The Purchaser and Vendor each agree to provide a release of this Agreement in the Vendor's standard form. If the Vendor and Purchaser do not consent to termination, the provisions of subsection 79(3) of the Act may be invoked by the Vendor.
- C.9 The Vendor and the Purchaser covenant and agree, notwithstanding the taking of possession, that all terms hereunder continue to be binding upon them and that the Vendor may enforce the provisions of the Occupancy Licence separate and apart from the purchase and sale provisions of this Agreement.
- C.10 The Purchaser acknowledges that the Vendor holds a fire insurance policy on the Condominium including all aspects of a standard unit only and not on any improvements or betterments made by or on behalf of the Purchaser. It is the responsibility of the Purchaser, after the Occupancy Date to insure the improvements or betterments to the Unit and to

replace and/or repair same if they are removed, injured or destroyed. The Vendor is not liable for the Purchaser's loss occasioned by fire, theft or other casualty, unless caused by the Vendor's willful conduct.

- C.11 The Purchaser agrees to indemnify the Vendor for all losses, costs and expenses incurred as a result of the Purchaser's neglect, damage or use of the Unit or the Condominium, or by reason of injury to any person or property in or upon the Unit or the Condominium resulting from the negligence of the Purchaser, members of his immediate family, servants, agents, invitees, tenants, contractors and licensees. The Purchaser agrees that should the Vendor elect to repair or redecorate all or any part of the Unit or the Condominium as a result of the Purchaser's neglect, damage or use of the Unit or Condominium, he will immediately reimburse the Vendor for the cost of doing same, the determination of need for such repairs or redecoration shall be at the discretion of the Vendor, and such costs may be added to the Purchase Price.
- C.12 In accordance with subsections 80(6)(d) and (e) of the Act, subject to strict compliance by the Purchaser with the requirements of occupancy set forth in this Agreement, the Purchaser shall not have the right to assign, sublet or in any other manner dispose of the Occupancy Licence during Interim Occupancy without the prior written consent of the Vendor which consent may be arbitrarily withheld. The Purchaser acknowledges that an administrative fee will be payable to the Vendor each time the Purchaser wishes to assign, sublet or dispose of the Occupancy License during Interim Occupancy.
- C.13 The provisions set forth in this Agreement, unless otherwise expressly modified by the terms of the Occupancy Licence, shall be deemed to form an integral part of the Occupancy Licence. In the event the Vendor elects to terminate the Occupancy Licence pursuant to this Agreement following substantial damage to the Unit and/or the Condominium, the Occupancy Licence shall terminate forthwith upon notice from the Vendor to the Purchaser. If the Unit and/or the Condominium can be repaired within a reasonable time following damages as determined by the Vendor (but not, in any event, to exceed one hundred and eighty (180) days) and the Unit is, during such period of repairs uninhabitable, the Vendor shall proceed to carry out the necessary repairs to the Unit and/or the Condominium with all due dispatch and the Occupancy Fee shall abate during the period when the Unit remains uninhabitable; otherwise, the Purchaser shall vacate the Unit and deliver up vacant possession to the Vendor and all moneys, to the extent provided for in paragraph 20 hereof (excluding the Occupancy Fee paid to the Vendor) shall be returned to the Purchaser. It is understood and agreed that the proceeds of all insurance policies held by the Vendor are for the benefit of the Vendor alone.

M:\08\080917\Masters\Agreement of Purchase and Sale (October 18 09).DOC

## SCHEDULE "D" TO AGREEMENT OF PURCHASE AND SALE

### WARNING CLAUSES

1. The Purchaser acknowledges that it is anticipated by the Declarant that in connection with the Declarant's application to the appropriate governmental authorities for draft plan of condominium approval certain requirements may be imposed upon the Declarant by various governmental authorities. These requirements (the "Requirements") usually relate to warning provisions to be given to Purchasers in connection with environmental or other concerns (such as warnings relating to noise levels, the proximity of the Condominium to major street, hydro transmission lines, garbage storage and pickup, school transportation, and similar matters). Accordingly, the Purchaser covenants and agrees that (1) on either the Closing Date or Unit Transfer Date, (as set out in the Agreement of Purchase and Sale executed by the Purchaser) as determined by the Declarant, the Purchaser shall execute any and all documents required by the Declarant acknowledging, inter alia, that the Purchaser is aware of the Requirements, and (2) if the Declarant is required to incorporate the Requirements into the final Condominium Documents the Purchaser shall accept the same, without in any way affecting this transaction.
2. The Purchaser is hereby advised that the Declarant's builder's risk and/or comprehensive liability insurance (effective prior to the registration of the Condominium), and the Condominium's master insurance policy (effective from and after the registration of the Condominium) will only cover the common elements and the standard unit and will not cover any betterments or improvements made to the standard unit, nor any furnishings or personal belongings of the Purchaser or other residents of the Unit, and accordingly the Purchaser should arrange for his or her own insurance coverage with respect to same, effective from and after the Closing Date, all at the Purchaser's sole cost and expense.
3. The Purchaser acknowledges and agrees that the Declarant (and any of its authorized agents, representatives and/or contractors), as well as one or more authorized representatives of the Condominium, shall be permitted to enter the Unit after Closing, from time to time, in order to enable the Declarant to correct outstanding deficiencies or incomplete work for which the Declarant is responsible, and to enable the Condominium to inspect the condition or state of repair of the Unit and undertake or complete any requisite repairs thereto (which the owner of the Unit has failed to do) in accordance with the Act.
4. The Purchaser acknowledges being advised of the following notices:
  - (i) Prospective purchasers are advised that pupils may be accommodated in temporary facilities and/or be directed to schools outside of the area;
  - (ii) Purchasers are advised that sufficient accommodation may not be available for students residing in this area and that you are notified that students may be accommodated in temporary facilities and/or bussed to existing facilities outside the area. The local District School Board may designate pick up points for the children to meet the bus on roads presently in existence or other pick up areas convenient to the Board.
  - (iii) This dwelling unit has been fitted with a forced air heating system and air conditioning. Air conditioning will allow window and exterior doors to remain closed, thereby ensuring that indoor sound levels are within the Municipality's and the Ministry of the Environment's noise criteria.
5. Without limiting the generality of the preceding subparagraph, the Purchaser is hereby advised that:
  - (i) noise levels caused by the Condominium's emergency generator, bank of elevators, garbage chutes, mechanical equipment, chiller/cooling tower, move-in bays and ancillary moving facilities and areas, and by the Condominium's indoor recreation facilities, may occasionally cause noise and inconvenience to the residential occupants; and
  - (ii) as and when other residential units in the Condominium are being completed and/or moved into, excessive levels of noise, vibration, dust and/or debris are possible, and same may accordingly temporarily cause noise and inconvenience to the residential occupants.
6. The Purchaser specifically acknowledges and agrees that the Condominium will be developed in accordance with any requirements that may be imposed from time to time by any Governmental Authorities and the proximity of the Lands to Park Street, Allen Street and King Street, and proposed Grand River Transit light rail operations may result in noise, vibration, electromagnetic interference, and stray current transmissions ("Interferences") to the Property and despite the inclusion of control features within the Condominium. Interferences from transit operations may continue to be of concern, occasionally interfering with some activities of the dwelling occupants in the Condominium. Purchasers are advised that Regional Municipality of Waterloo proposes to construct light rail operations along King Street and/or Caroline Street in the future.
7. It is further acknowledged that one or more of the Development Agreements may require the Declarant to provide the Purchaser with certain notices, including without limitation, notices regarding such matters as land use, the maintenance of retaining walls, landscaping features and/or fencing, noise abatement features, garbage storage and pick-up, school transportation, and noise/vibration levels from adjacent roadways and/or nearby railway lines or airports. The Purchaser agrees to be bound by the contents of any such notice(s), whether given to the Purchaser at the time that this Agreement has been entered into, or at any time thereafter up to the Title Transfer Date, and the Purchaser further covenants and agrees to execute, forthwith upon the Declarant's request, an express acknowledgment confirming the Purchaser's receipt of such notice(s) in accordance with (and in full compliance of) such provisions of the Development Agreement(s), if and when required to do so by the Declarant.
8. The Purchaser acknowledges that the Declarant reserves the right to increase or decrease the final number of residential, parking, locker, and/or other ancillary units intended to be created within the Condominium, as well as the right to alter the design, style, size and/or configuration of the residential units ultimately comprised within the Condominium which have not yet been sold by the Declarant to any unit purchaser(s), all in the Declarant's sole discretion, and the Purchaser expressly acknowledges and agrees to the foregoing, provided that the final budget for the first year following registration of the Condominium is prepared in such a manner so that any such variance in the residential/parking/locker and/or other ancillary unit count will not affect, in any material or substantial way, the percentages of common expenses and common interests allocated and attributable to the residential, parking and/or

locker units sold by the Declarant to the Purchaser. Without limiting the generality of the foregoing, the Purchaser further acknowledges and agrees that one or more residential units situate adjacent to one another may be combined or amalgamated prior to the registration of the Condominium, in which case the common expenses and common interests attributable to such proposed former units will be incorporated into one figure or percentage in respect of the final combined unit, and the overall residential unit count of the Condominium will be varied and adjusted accordingly. None of the foregoing changes or revisions (if implemented) shall in any way be considered or construed as a material change to the disclosure statement prepared and delivered by the Declarant to the Purchaser in connection with this transaction.

9. The Purchaser hereby acknowledges and agrees that the Declarant cannot guarantee (and will not be responsible for) the arrangement of a suitable move-in time for purposes of accommodating the Purchaser's occupancy of the residential unit on the Closing Date, (or any acceleration or extension thereof as hereinbefore provided), and that the Purchaser shall be solely responsible for directly contacting the Declarant's customer service office in order to make suitable booking arrangements with respect to the Condominium's service elevator, if applicable (with such booking being allotted on a "first come, first served" basis), and under no circumstances shall the Purchaser be entitled to any claim, refund, credit, reduction/abatement or set-off whatsoever against any portion of the Purchase Price, or against any portion of the common expenses or other adjustments with respect thereto (nor with respect to any portion of the monthly occupancy fees so paid or payable, if applicable) as a result of the service elevator not being available to accommodate the Purchaser moving into the Condominium on (or within any period of time after) the Closing Date, (or any acceleration or extension thereof, as aforesaid).
10. The Declarant/Vendor shall have the right to substitute any level in the Condominium with an alternative floor plate containing a modified design of units and/or number of units on the level. In the event that such modification becomes necessary, there shall be a reallocation of each owner's proportionate percentage and the Budget shall be modified accordingly. The Purchaser acknowledges that none of the foregoing changes or revisions (if implemented) shall in any way be considered or construed as a material change to the disclosure statement prepared and delivered by the Declarant to the Purchaser in connection with this transaction.
11. Purchasers of Residential Units located on Levels 1, 4 and 5 of the Condominium acknowledge being advised that it is the Declarant's current intention to incorporate the Condominium's amenity space and Parking Facility within or adjacent to this level, and accordingly, Purchasers are advised that typical noise associated with the use of the amenity space and Parking Facility may occasionally interfere with some activities within the Unit. Purchasers acknowledge that they have reviewed the draft condominium plan provided to them within the Disclosure Book and, in consideration of both their location on a particular level and their location in relation to the amenities and parking facility are satisfied with respect to their proximity to same.
12. Purchasers of Residential Units located on Level 1 of the Condominium acknowledge being advised that it is the Declarant's current intention to incorporate the Condominium's parking facility and amenity space, and to locate certain mechanical facilities, loading area and refuse holding room within areas adjacent to said Units, and accordingly, Purchasers are advised that typical noise associated with the use of foregoing may occasionally interfere with some activities within the Unit. Purchasers acknowledge that they have reviewed the draft condominium plan provided to them within the Disclosure Book and, in consideration of both their location on a particular level and their location adjacent to the parking facility, amenities, mechanical facilities, loading area and refuse holding room, are satisfied with respect to their proximity to same.
13. Purchasers of Residential Units 1 to 9 on Level 1 are advised that they may be required to bring their refuse from their respective units to the refuse holding room in Level 1 of the Condominium.
14. Purchasers are advised that the Condominium is located in proximity to the Trans-Canada Trail.
15. Purchasers are notified that the Property is located in proximity to businesses and restaurants, including the Brick Brewery, which may produce odours that may be noticed by occupants of the Property from time to time.
16. Purchasers are advised that the Declarant's marketing material and site drawings and renderings ("Marketing Material") which they may have reviewed prior to the execution of this Agreement remains conceptual and that final building plans are subject to the final review and approval of any applicable governmental authority and the Declarant's design consultants and engineers, and accordingly such Marketing Material does not form part of this Agreement or the Vendor's obligations hereunder.





Property 144 Park - Uptown Waterloo  
Waterloo, Ontario

## Statement Of Critical Dates Delayed Occupancy Warranty

This Statement of Critical Dates forms part of the Addendum to which it is attached, which in turn forms part of the agreement of purchase and sale between the Vendor and the Purchaser relating to the Property. The Vendor must complete all blanks set out below.

**NOTE TO HOME BUYERS:** Please visit Tarion's website: [www.tarion.com](http://www.tarion.com) for important information about all Tarion's warranties including the Delayed Occupancy Warranty, the Pre-Delivery Inspection and other matters of interest to new home buyers. You can also obtain a copy of the Homeowner Information Package which is strongly recommended as essential reading for all home buyers. The website features a calculator which will assist you in confirming the various Critical Dates related to the occupancy of your condominium unit.

**VENDOR** 144 Park Ltd.  
Full Name(s)  
**PURCHASER** Laurie and Ryan CyranKiewicz  
Full Name(s)

### 1. Critical Dates

The First Tentative Occupancy Date, which is the date that the Vendor anticipates the condominium home will be completed and ready to move in, is:

the 30 day of April, 20 12.

The Vendor can delay Occupancy on one or more occasions by setting a subsequent Tentative Occupancy Date, in accordance with section 3 of the Addendum by giving proper written notice as set out in section 3.

By no later than 30 days after completion of the roof slab or of the roof trusses and sheathing, as the case may be, with 90 days prior written notice, the Vendor shall set either (i) a Final Tentative Occupancy Date; or (ii) a Firm Occupancy Date.

If the Vendor sets a Final Tentative Occupancy Date but cannot provide Occupancy by the Final Tentative Occupancy Date, then the Vendor shall set a Firm Occupancy Date that is no later than 120 days after the Final Tentative Occupancy Date, with proper written notice as set out in section 3 below.

*If the Vendor cannot provide Occupancy by the Firm Occupancy Date, then the Purchaser is entitled to delayed occupancy compensation (see section 9 of the Addendum) and the Vendor must set a Delayed Occupancy Date which cannot be later than the Outside Occupancy Date.*

The Outside Occupancy Date, which is the latest date by which the Vendor agrees to provide Occupancy, is:

the 31 day of October, 20 13.

### 2. Notice Period for an Occupancy Delay

Changing an Occupancy date requires proper written notice. The Vendor, without the Purchaser's consent, may delay occupancy one or more times in accordance with section 3 of the Addendum and no later than the Outside Occupancy Date.

Notice of a delay beyond the First Tentative Occupancy Date must be given no later than: (i.e., 90 days before the First Tentative Occupancy Date), or else the First Tentative Occupancy Date automatically becomes the Firm Occupancy Date.

the 31 day of January, 20 12.

### 3. Purchaser's Termination Period

If the condominium home is not complete by the Outside Occupancy Date, and the Vendor and the Purchaser have not otherwise agreed, then the Purchaser can terminate the transaction during a period of 30 days thereafter (the "Purchaser's Termination Period"), which period could end as late as:

the 30 day of November, 20 13.

If the Purchaser terminates the transaction during the Purchaser's Termination Period, then the Purchaser is entitled to delayed occupancy compensation and to a full refund of all monies paid plus interest (see sections 9, 11 and 12 of the Addendum).

*Note: Anytime a Critical Date is set or changed as permitted in the Addendum, other Critical Dates may change as well. At any given time the parties must refer to the most recent agreement or written notice that sets a Critical Date, and calculate revised Critical Dates using the formulas contained in the Addendum. Critical Dates can also change if there are unavoidable delays (see section 7 of the Addendum).*

Acknowledged this 23<sup>rd</sup> day of Jan, 20 10.

VENDOR: [Signature]

PURCHASER: [Signature]

## Addendum to Agreement of Purchase and Sale Delayed Occupancy Warranty

This addendum, including the accompanying Statement of Critical Dates (the "Addendum"), forms part of the agreement of purchase and sale (the "Purchase Agreement") between the Vendor and the Purchaser relating to the Property. It contains important provisions that are part of the delayed occupancy warranty provided by the Vendor in accordance with the *Ontario New Home Warranties Plan Act* (the "Act"). If there are any differences between the provisions in the Addendum and the Purchase Agreement, then the Addendum provisions shall prevail. **PRIOR TO SIGNING THE PURCHASE AGREEMENT OR ANY AMENDMENT TO IT, THE PURCHASER SHOULD SEEK ADVICE FROM A LAWYER WITH RESPECT TO THE PURCHASE AGREEMENT OR AMENDING AGREEMENT, THE ADDENDUM AND THE DELAYED OCCUPANCY WARRANTY.**

The Vendor shall complete all blanks set out below.

<b>VENDOR</b>			
144 Park Ltd.			
<small>Full Name(s)</small>			
39278	8791 Woodbine Avenue, Suite 100		
<small>Tarion Registration Number</small>	<small>Address</small>		
905-944-0907	Markham	Ontario	L3R 0P4
<small>Phone</small>	<small>City</small>	<small>Province</small>	<small>Postal Code</small>
905-944-0916	jbolton@madycorp.com		
<small>Fax</small>	<small>Email</small>		
<b>PURCHASER</b>			
Ryan and Laurie Cyranekewicz			
<small>Full Name(s)</small>			
3-6 Sims Estate Place			
<small>Address</small>			
519-654-6362	Kitchener	Ontario	
<small>Phone</small>	<small>City</small>	<small>Province</small>	<small>Postal Code</small>
<small>Fax</small>	<small>Email</small>		
<b>PROPERTY DESCRIPTION</b>			
21 Allen Street West (current) - 144 Park Street (proposed)			
<small>Municipal Address</small>			
Waterloo	Ontario	N2L 1C7	
<small>City</small>	<small>Province</small>	<small>Postal Code</small>	
Lots 1-6, inclusive, on Plan 186, save and except Parts 1 and 2 on 58R-10656; Waterloo being all of PIN No. 22417-0127 (LT)			
<small>Short Legal Description</small>			
<b>INFORMATION REGARDING THE PROPERTY</b>			
The Vendor confirms that:			
(a) The Vendor has obtained Formal Zoning Approval for the Building.			<input type="radio"/> Yes <input checked="" type="radio"/> No
If no, the Vendor shall give written notice to the Purchaser within 10 days after the date that Formal Zoning Approval for the Building is obtained.			
(b) Commencement of Construction: <input type="radio"/> has occurred; or <input checked="" type="radio"/> is expected to occur by the 30th day of April, 2010.			
The Vendor shall give written notice to the Purchaser within 10 days after the actual date of Commencement of Construction.			

**1. Definitions**

- "Building" means the condominium building or buildings contemplated by the Purchase Agreement, in which the Property is located or is proposed to be located.
- "Business Day" means any day other than: Saturday; Sunday; New Year's Day; Family Day; Good Friday; Easter Monday; Victoria Day; Canada Day; Civic Holiday; Labour Day; Thanksgiving Day; Remembrance Day; Christmas Day; Boxing Day; and any special holiday proclaimed by the Governor General or the Lieutenant Governor, and where New Year's Day, Canada Day or Remembrance Day falls on a Saturday or Sunday, the following Monday is not a Business Day, and where Christmas Day falls on a Saturday or Sunday, the following Monday and Tuesday are not Business Days, and where Christmas Day falls on a Friday, the following Monday is not a Business Day.
- "Commencement of Construction" means the commencement of construction of foundation components or elements (such as footings, rafts or piles) for the Building.
- "Critical Dates" means the First Tentative Occupancy Date, any subsequent Tentative Occupancy Date, the Final Tentative Occupancy Date, the Firm Occupancy Date, the Delayed Occupancy Date, the Outside Occupancy Date and the last day of the Purchaser's Termination Period.
- "Delayed Occupancy Date" means the date, set in accordance with section 6, on which the Vendor agrees to provide Occupancy, in the event the Vendor cannot provide Occupancy on the Firm Occupancy Date.
- "Early Termination Conditions" means the types of conditions listed in Schedule A.
- "Firm Occupancy Date" means the firm date on which the Vendor agrees to provide Occupancy as set in accordance with this Addendum.
- "First Tentative Occupancy Date" means the date on which the Vendor, at the time of signing the Purchase Agreement, anticipates that the condominium home will be complete and ready for Occupancy, as set out in the Statement of Critical Dates.
- "Final Tentative Occupancy Date" means the last Tentative Occupancy Date that may be set, in accordance with paragraph 3(d).
- "Formal Zoning Approval" occurs when the zoning by-law required in order to construct the Building has been approved by all relevant governmental authorities having jurisdiction, and the period for appealing the approvals has elapsed and/or any appeals have been dismissed or the approval affirmed.
- "Occupancy" means the right to use or occupy a proposed or registered condominium home in accordance with the Purchase Agreement.
- "Outside Occupancy Date" means the latest date that the Vendor agrees, at the time of signing the Purchase Agreement, to provide Occupancy to the Purchaser, as set out in the Statement of Critical Dates.
- "Property" or "condominium home" means the condominium dwelling unit being acquired by the Purchaser from the Vendor, and its appurtenant interest in the common elements.
- "Purchaser's Termination Period" means the 30-day period during which the Purchaser may terminate the Purchase Agreement for delay, in accordance with paragraph 11(b).
- "Statement of Critical Dates" means the Statement of Critical Dates attached to or accompanying this Addendum (in form to be determined by the Tarion Registrar from time to time). The Statement of Critical Dates must be signed by both the Vendor and Purchaser.
- "Tentative Occupancy Date" has the meaning given to it in paragraph 3(c).
- "The Act" means the *Ontario New Home Warranties Plan Act* including regulations, as amended from time to time.
- "Unavoidable Delay" means an event which delays Occupancy which is a strike, fire, explosion, flood, act of God, civil insurrection, act of war, act of terrorism or pandemic, plus any period of delay directly caused by the event, which are beyond the reasonable control of the Vendor and are not caused or contributed to by the fault of the Vendor.
- "Unavoidable Delay Period" means the number of days between the Purchaser's receipt of written notice of the commencement of the Unavoidable Delay, as required by paragraph 7(b), and the date on which the Unavoidable Delay concludes.

**2. Early Termination Conditions**

- (a) The Vendor and Purchaser may include conditions in the Purchase Agreement that, if not satisfied, give rise to early termination of the Purchase Agreement, but only in the limited way described in this section.
- (b) The Vendor is not permitted to include any conditions in the Purchase Agreement other than the types of Early Termination Conditions listed in Schedule A; and/or the conditions referred to in paragraphs 2(h), (i) and (j) below. Any other condition included in a Purchase Agreement for the benefit of the Vendor that is not expressly permitted under Schedule A or paragraphs 2(h) or (i) is deemed null and void and is not enforceable by the Vendor, but does not affect the validity of the balance of the Purchase Agreement.
- (c) The Vendor confirms that:

- (i) This Purchase Agreement is subject to Early Termination Conditions that, if not satisfied (or waived, if applicable), will result in the automatic termination of the Purchase Agreement. ☑ Yes ○ No
- (ii) If yes, the Early Termination Conditions are as follows. The obligation of each of the Purchaser and Vendor to complete this purchase and sale transaction is subject to satisfaction (or waiver, if applicable) of the following conditions:

Condition #1 (if applicable)

Description of the Early Termination Condition: see appendix

The Approving Authority (as that term is defined in Schedule A) is: see appendix

The date by which Condition #1 is to be satisfied is the see appendix day of \_\_\_\_\_, 20\_\_\_\_.

Condition #2 (if applicable)

Description of the Early Termination Condition: see appendix

The Approving Authority (as that term is defined in Schedule A) is: see appendix

The date by which Condition #2 is to be satisfied is the \_\_\_\_\_ day of \_\_\_\_\_, 20\_\_\_\_.

The date for satisfaction of any Early Termination Condition cannot be later than 90 days before the First Tentative Occupancy Date, and will be deemed to be 90 days before the First Tentative Occupancy Date if no date is specified or if the date specified is later than 90 days before the First Tentative Occupancy Date. This time limitation does not apply to the condition in subparagraph 1(b)(iv) of Schedule A which must be satisfied or waived by the Vendor within 60 days following signing of the Purchase Agreement.

Note: The parties must add additional pages as an appendix to this Addendum if there are additional Early Termination Conditions.

- (d) There are no Early Termination Conditions applicable to this Purchase Agreement other than those identified in subparagraph 2(c)(ii) and any appendix listing additional Early Termination Conditions.
- (e) The Vendor agrees to take all commercially reasonable steps within its power to satisfy the Early Termination Conditions listed in subparagraph 2(c)(ii).
- (f) For conditions under paragraph 1(a) of Schedule A the following applies:
- (i) conditions in paragraph 1(a) of Schedule A may not be waived by either party;

**2. Early Termination Conditions (continued)**

- (ii) the Vendor shall provide written notice not later than five (5) Business Days after the date specified for satisfaction of a condition that: (A) the condition has been satisfied; or (B) the condition has not been satisfied (together with reasonable details and backup materials) and that as a result the Purchase Agreement is terminated; and
  - (iii) if notice is not provided as required by subparagraph (ii) above then the condition is deemed not satisfied and the Purchase Agreement is terminated.
- (g) For conditions under paragraph 1(b) of Schedule A the following applies:
- (i) conditions in paragraph 1(b) of Schedule A may be waived by the Vendor;
  - (ii) the Vendor shall provide written notice on or before the date specified for satisfaction of the condition that: (A) the condition has been satisfied or waived; or (B) the condition has not been satisfied nor waived, and that as a result the Purchase Agreement is terminated; and
  - (iii) if notice is not provided as required by subparagraph (ii) above then the condition is deemed satisfied or waived and the Purchase Agreement will continue to be binding on both parties.
- (h) The Purchase Agreement may be conditional until closing (transfer to the Purchaser of the title to the condominium home) upon compliance with the subdivision control provisions (section 50) of the *Planning Act* (Ontario) or by virtue of registration of the Building under the *Condominium Act* (Ontario), which compliance shall be obtained by the Vendor at its sole expense, on or before closing.
- (i) The Purchaser is cautioned that there may be other conditions in the Purchase Agreement that allow the Vendor to terminate the Purchase Agreement due to the fault of the Purchaser.
- (j) The Purchase Agreement may include any condition that is for the sole benefit of the Purchaser and that is agreed to by the Vendor (i.e., the sale of an existing dwelling, Purchaser financing or a basement walkout). The Purchase Agreement may specify that the Purchaser has a right to terminate the Purchase Agreement if any such condition is not met, and may set out the terms on which termination by the Purchaser may be effected.

**3. Setting Tentative Occupancy Dates and the Firm Occupancy Date**

- (a) **Completing Construction Without Delay:** The Vendor shall take all reasonable steps to complete construction of the Building subject to all prescribed requirements, to provide Occupancy of the condominium home without delay, and to register without delay the declaration and description in respect of the Building.
- (b) **First Tentative Occupancy Date:** The Vendor shall identify the First Tentative Occupancy Date in the Statement of Critical Dates attached to this Addendum at the time the Purchase Agreement is signed.
- (c) **Subsequent Tentative Occupancy Dates:** The Vendor may, in accordance with this section, extend the First Tentative Occupancy Date on one or more occasions, by setting a subsequent Tentative Occupancy Date. The Vendor shall give written notice of any subsequent Tentative Occupancy Date to the Purchaser no later than 90 days before the existing Tentative Occupancy Date (which in this Addendum may include the First Tentative Occupancy Date), or else the existing Tentative Occupancy Date shall for all purposes be the Firm Occupancy Date. A subsequent Tentative Occupancy Date can be any Business Day on or before the Outside Occupancy Date.
- (d) **Final Tentative Occupancy Date:** By no later than 30 days after completion of the roof slab or of the roof trusses and sheathing of the Building, as the case may be, the Vendor shall by written notice to the Purchaser set either (i) a Final Tentative Occupancy Date; or (ii) a Firm Occupancy Date. If the Vendor does not do so, the existing Tentative Occupancy Date shall for all purposes be the Firm Occupancy Date. The Vendor shall give written notice of the Final Tentative Occupancy Date or Firm Occupancy Date, as the case may be, to the Purchaser no later than 90 days before the existing Tentative Occupancy Date, or else the existing Tentative Occupancy Date shall for all purposes be the Firm Occupancy Date. The Final Tentative Occupancy Date or Firm Occupancy Date, as the case may be, can be any Business Day on or before the Outside Occupancy Date.
- (e) **Firm Occupancy Date:** If the Vendor has set a Final Tentative Occupancy Date but cannot provide Occupancy by the Final Tentative Occupancy Date then the Vendor shall set a Firm Occupancy Date that is no later than 120 days after the Final Tentative Occupancy Date. The Vendor shall give written notice of the Firm Occupancy Date to the Purchaser no later than 90 days before the Final Tentative Occupancy Date, or else the Final Tentative Occupancy Date shall for all purposes be the Firm Occupancy Date. The Firm Occupancy Date can be any Business Day on or before the Outside Occupancy Date.
- (f) **Notice:** Any notice given by the Vendor under paragraph (c), (d) or (e) must set out the revised Critical Date, as applicable, and state that the setting of such date may change other future Critical Dates, as applicable, in accordance with the terms of the Addendum.

**4. Changing the Firm Occupancy Date – Three Ways**

- (a) The Firm Occupancy Date, once set or deemed to be set in accordance with section 3, can be changed only:
- (i) by the mutual written agreement of the Vendor and Purchaser in accordance with section 5;
  - (ii) by the Vendor setting a Delayed Occupancy Date in accordance with section 6; or
  - (iii) as the result of an Unavoidable Delay of which proper written notice is given in accordance with section 7.
- (b) If a new Firm Occupancy Date is set in accordance with section 5 or 7, then the new date is the "Firm Occupancy Date" for all purposes in this Addendum.

**5. Changing Critical Dates – By Mutual Agreement**

- (a) This Addendum sets out a structure for setting, extending and/or accelerating Occupancy dates, which cannot be altered contractually except as set out in this section 5 and in paragraph 7(c). For greater certainty, this Addendum does not restrict any extensions of the closing date (i.e., title transfer date) where Occupancy of the condominium home has already been given to the Purchaser.
- (b) The Vendor and Purchaser may at any time, after signing the Purchase Agreement, mutually agree in writing to accelerate or extend a Firm Occupancy Date or a Delayed Occupancy Date in each case to a new specified calendar date. The amendment must comply with the requirements of section 10.
- (c) The Vendor and Purchaser may at any time after signing the Purchase Agreement mutually agree in writing to accelerate the First Tentative Occupancy Date and correspondingly reset all the Critical Dates provided that:
- (i) the mutual amendment is signed at least 180 days prior to the First Tentative Occupancy Date;
  - (ii) all the Critical Dates including the Outside Occupancy Date are moved forward by the same number of days (subject to adjustment so that Critical Dates fall on Business Days);
  - (iii) a new Statement of Critical Dates is signed by both parties at the time the amendment is signed and a copy is provided to the Purchaser; and
  - (iv) the Purchaser is given a three (3) Business Day period in which to review the amendment after signing and if not satisfied with the amendment may terminate the amendment (but not the balance of the Purchase Agreement), upon written notice to the Vendor within such 3-day period.
- Any such amendment must be by mutual agreement and, for greater certainty, neither party has any obligation to enter into such an amendment.
- (d) A Vendor is permitted to include a provision in the Purchase Agreement allowing the Vendor a one-time unilateral right to extend a Firm Occupancy Date or Delayed Occupancy Date, as the case may be, for one (1) Business Day to avoid the necessity of tender where a Purchaser is not ready to complete the transaction on the Firm Occupancy Date or Delayed Occupancy Date, as the case may be. Delayed occupancy compensation will not be payable for such period and the Vendor may not impose any penalty or interest charge upon the Purchaser with respect to such extension.
- (e) The Vendor and Purchaser may agree in the Purchase Agreement to any unilateral extension or acceleration rights that are for the benefit of the Purchaser.

**6. Changing the Firm Occupancy Date – By Setting a Delayed Occupancy Date**

- (a) If the Vendor cannot provide Occupancy on the Firm Occupancy Date and sections 5 and 7 do not apply, the Vendor shall select and give written notice to the Purchaser of a Delayed Occupancy Date in accordance with this section, and delayed occupancy compensation is payable in accordance with section 9.

**6. Changing the Firm Occupancy Date – By Setting a Delayed Occupancy Date (continued)**

- (b) The Delayed Occupancy Date may be any Business Day after the date the Purchaser receives written notice of the Delayed Occupancy Date but not later than the Outside Occupancy Date.
- (c) The Vendor shall give written notice to the Purchaser of the Delayed Occupancy Date as soon as the Vendor knows that it will be unable to provide Occupancy on the Firm Occupancy Date, and in any event no later than 10 days before the Firm Occupancy Date, failing which delayed occupancy compensation is payable from the date that is 10 days before the Firm Occupancy Date, in accordance with paragraph 9(c).
- (d) If a Delayed Occupancy Date is set and the Vendor cannot provide Occupancy on the Delayed Occupancy Date, the Vendor shall select and give written notice to the Purchaser of a new Delayed Occupancy Date, unless the delay arises due to Unavoidable Delay under section 7 or is mutually agreed upon under section 5, in which case the requirements of these sections must be met. Paragraphs 6(b) and 6(c) above apply with respect to the setting of the new Delayed Occupancy Date.
- (e) Nothing in this section affects the right of the Purchaser or Vendor to terminate the Purchase Agreement on the bases set out in section 11.

**7. Extending Dates – Due to Unavoidable Delay**

- (a) If Unavoidable Delay occurs, the Vendor may extend Critical Dates by no more than the length of the Unavoidable Delay Period, without the approval of the Purchaser and without the requirement to pay delayed occupancy compensation in connection with the Unavoidable Delay, provided the requirements of this section are met.
- (b) If the Vendor wishes to extend Critical Dates on account of Unavoidable Delay, the Vendor shall provide written notice to the Purchaser setting out a brief description of the Unavoidable Delay, and an estimate of the duration of the delay. Once the Vendor knows or ought reasonably to know that an Unavoidable Delay has commenced, the Vendor shall provide written notice to the Purchaser by the earlier of 10 days thereafter, and the next Critical Date.
- (c) As soon as reasonably possible, and no later than 10 days after the Vendor knows or ought reasonably to know that an Unavoidable Delay has concluded, the Vendor shall provide written notice to the Purchaser setting out a brief description of the Unavoidable Delay, identifying the date of its conclusion, and setting new Critical Dates. The new Critical Dates are calculated by adding to the then next Critical Date the number of days of the Unavoidable Delay Period (the other Critical Dates changing accordingly), provided that the Firm Occupancy Date or Delayed Occupancy Date, as the case may be, must be at least 10 days after the day of giving notice unless the parties agree otherwise. Either the Vendor or the Purchaser may request in writing an earlier Firm Occupancy Date or Delayed Occupancy Date, and the other party's consent to the earlier date shall not be unreasonably withheld.
- (d) If the Vendor fails to give written notice of the conclusion of the Unavoidable Delay in the manner required by paragraph 7(c), the notice is ineffective, the existing Critical Dates are unchanged, and any delayed occupancy compensation payable under section 9 is payable from the existing Firm Occupancy Date.
- (e) Any notice setting new Critical Dates given by the Vendor under this section must set out the revised next Critical Date and state that the setting of such date may change other future Critical Dates, as applicable, in accordance with the terms of the Addendum.

**8. Building Code – Conditions of Occupancy**

- (a) On or before the date of Occupancy, the Vendor shall deliver to the Purchaser:
  - (i) where a registered code agency has been appointed for the building or part of the building under the *Building Code Act* (Ontario), a final certificate with respect to the condominium home that contains the prescribed information as required by s. 11(3) of the *Building Code Act*; or
  - (ii) where a registered code agency has not been so appointed, either:
    - (A) an Occupancy Permit (as defined in paragraph (d)) for the condominium home; or
    - (B) a signed written confirmation by the Vendor that: (i) provisional or temporary occupancy of the condominium home has been authorized under Article 1.3.3.1 of Division C of the *Building Code*; or (ii) the conditions for residential occupancy of the condominium home as set out in s. 11 of the *Building Code Act* or Article 1.3.3.2 of Division C of the *Building Code*, as the case may be (the "Conditions of Occupancy") have been fulfilled.
- (b) Notwithstanding the requirements of paragraph (a), to the extent that the Purchaser and the Vendor agree that the Purchaser shall be responsible for certain Conditions of Occupancy (the "Purchaser Obligations"):
  - (i) the Purchaser may not refuse to take Occupancy on the basis that the Purchaser Obligations have not been completed;
  - (ii) the Vendor shall deliver to the Purchaser, upon fulfilling the Conditions of Occupancy (other than the Purchaser Obligations), a signed written confirmation that the Vendor has fulfilled such Conditions of Occupancy; and
  - (iii) if the Purchaser and Vendor have agreed that the Conditions of Occupancy (other than the Purchaser Obligations) are to be fulfilled prior to Occupancy, then the Vendor shall provide the signed written confirmation required by subparagraph (ii) on or before the date of Occupancy.
- (c) If the Vendor cannot satisfy the requirements of paragraph (a) or subparagraph (b)(iii), then the Vendor shall set a Delayed Occupancy Date (or new Delayed Occupancy Date) on a date that the Vendor reasonably expects to have satisfied the requirements of paragraph (a) or subparagraph (b)(iii), as the case may be. In setting the Delayed Occupancy Date (or new Delayed Occupancy Date), the Vendor shall comply with the requirements of section 6, and delayed occupancy compensation shall be payable in accordance with section 9. Despite the foregoing, delayed occupancy compensation shall not be payable for a delay under this paragraph (c) if the inability to satisfy the requirements of subparagraph (b)(iii) is because the Purchaser has failed to satisfy the Purchaser Obligations.
- (d) For the purposes of this section, an "Occupancy Permit" means any written document, however styled, whether final, provisional or temporary, provided by the chief building official (as defined in the *Building Code Act*) or a person designated by the chief building official, that evidences the fact that authority to occupy the condominium home has been granted.

**9. Delayed Occupancy Compensation**

- (a) The Vendor warrants to the Purchaser that, if Occupancy is delayed beyond the Firm Occupancy Date (other than by mutual agreement or as a result of Unavoidable Delay as permitted under sections 5 or 7), then the Vendor shall compensate the Purchaser for all costs incurred by the Purchaser as a result of the delay up to a total amount of \$7,500, which amount includes payment to the Purchaser of \$150 a day for living expenses for each day of delay until the date of Occupancy or the date of termination of the Purchase Agreement, as applicable under paragraph (b).
- (b) Delayed occupancy compensation is payable only if: (i) Occupancy occurs; or (ii) the Purchase Agreement is terminated or deemed to have been terminated under paragraphs 11(b), (c) or (e) of this Addendum. Delayed occupancy compensation is payable only if the Purchaser's claim is made to Tarion in writing within one (1) year after Occupancy, or after termination of the Purchase Agreement, as the case may be, and otherwise in accordance with this Addendum. Compensation claims are subject to any further conditions set out in the Act.
- (c) If the Vendor gives written notice of a Delayed Occupancy Date to the Purchaser less than 10 days before the Firm Occupancy Date, contrary to the requirements of paragraph 6(c), then delayed occupancy compensation is payable from the date that is 10 days before the Firm Occupancy Date.
- (d) Living expenses are direct living costs such as for accommodation and meals. Receipts are not required in support of a claim for living expenses, as a set daily amount of \$150 per day is payable. The Purchaser must provide receipts in support of any claim for other delayed occupancy compensation, such as for moving and storage costs. Submission of false receipts disentitles the Purchaser to any delayed occupancy compensation in connection with a claim.
- (e) If delayed occupancy compensation is payable, the Purchaser may make a claim to the Vendor for that compensation within 180 days after Occupancy and shall include all receipts (apart from living expenses) which evidence any part of the Purchaser's claim. The Vendor shall assess the Purchaser's claim by determining the amount of delayed occupancy compensation payable based on the rules set out in section 9 and the receipts provided by the Purchaser, and the Vendor shall promptly provide that assessment information to the Purchaser. The Purchaser and the Vendor shall use reasonable efforts to settle the claim and when the claim is settled, the Vendor shall prepare an acknowledgement signed by both parties which:
  - (i) includes the Vendor's assessment of the delayed occupancy compensation payable;

**9. Delayed Occupancy Compensation (continued)**

- (ii) describes in reasonable detail the cash amount, goods, services, or other consideration which the Purchaser accepts as compensation (the "Compensation"), if any; and
  - (iii) contains a statement by the Purchaser that the Purchaser accepts the Compensation in full satisfaction of any delayed occupancy compensation payable by the Vendor.
- A true copy of the acknowledgement (showing clearly the municipal address and enrolment number of the condominium home on the first page) shall be provided to Tarion by the Vendor within 30 days after execution of the acknowledgment by the parties.
- (f) If the Vendor and Purchaser cannot agree as contemplated in paragraph 9(e), then to make a claim to Tarion the Purchaser must file a claim with Tarion in writing within one (1) year after Occupancy. A claim may also be made and the same rules apply if the sales transaction is terminated under paragraphs 11(b), (c) or (e) in which case, the deadline is 180 days after termination for a claim to the Vendor and one (1) year after termination for a claim to Tarion.

**10. Changes to Critical Dates**

- (a) Whenever the parties by mutual agreement extend or accelerate either the Firm Occupancy Date or the Delayed Occupancy Date this section applies.
- (b) If the change involves acceleration of either the Firm Occupancy Date or the Delayed Occupancy Date, then the amending agreement must set out each of the Critical Dates (as changed or confirmed).
- (c) If the change involves extending either the Firm Occupancy Date or the Delayed Occupancy Date, then the amending agreement shall:
  - (i) disclose to the Purchaser that the signing of the amendment may result in the loss of delayed occupancy compensation as described in section 9 above;
  - (ii) unless there is an express waiver of compensation, describe in reasonable detail the cash amount, goods, services, or other consideration which the Purchaser accepts as compensation (the "Compensation"); and
  - (iii) contain a statement by the Purchaser that the Purchaser waives compensation or accepts the above noted Compensation, in either case, in full satisfaction of any delayed occupancy compensation payable by the Vendor for the period up to the new Firm Occupancy Date or Delayed Occupancy Date.
- (d) If the Purchaser for his or her own purposes requests a change of date or dates, then paragraph 10(c) shall not apply.

**11. Termination of the Purchase Agreement**

- (a) The Vendor and the Purchaser may terminate the Purchase Agreement by mutual written consent, such written consent to be given at the time of the termination.
- (b) If for any reason (other than breach of contract by the Purchaser) Occupancy has not been given to the Purchaser by the Outside Occupancy Date, then the Purchaser has 30 days to terminate the Purchase Agreement by written notice to the Vendor. If the Purchaser does not provide written notice of termination within such 30-day period, then the Purchase Agreement shall continue to be binding on both parties and the Delayed Occupancy Date shall be the date set by the Vendor under paragraph 6(b), regardless of whether such date is beyond the Outside Occupancy Date.
- (c) If calendar dates for the applicable Critical Dates are not inserted in the Statement of Critical Dates; or if any date for Occupancy is expressed in the Purchase Agreement or in any other document to be subject to change depending upon the happening of an event (other than as permitted in this Addendum), then the Purchaser may terminate the Purchase Agreement by written notice to the Vendor.
- (d) The Purchase Agreement may be terminated in accordance with the requirements of section 2.
- (e) Nothing in this Addendum derogates from any right of termination that either the Purchaser or the Vendor may have at law or in equity on the basis of, for example, frustration of contract or fundamental breach of contract.
- (f) Except as permitted in this section, the Purchase Agreement may not be terminated by reason of delay in Occupancy alone.

**12. Return of Monies Paid on Termination**

- (a) If the Purchase Agreement is terminated (other than as a result of breach of contract by the Purchaser), the Vendor shall return all monies paid by the Purchaser including deposit(s) and monies for upgrades and extras, within 10 days of such termination, with interest from the date each amount was paid to the Vendor to the date of return to the Purchaser. The Purchaser cannot be compelled by the Vendor to execute a release of the Vendor and/or a termination agreement as a prerequisite to obtaining the return of monies payable as a result of termination of the Purchase Agreement under this paragraph.
- (b) The rate of interest payable on the Purchaser's monies shall be calculated in accordance with the *Condominium Act*.
- (c) Notwithstanding paragraphs 12(a) and 12(b), if either party initiates legal proceedings to contest termination of the Purchase Agreement or the return of monies paid by the Purchaser, and obtains a legal determination, such amounts and interest shall be payable as determined in those proceedings.

**13. Addendum Prevails**

The Addendum forms part of the Purchase Agreement. The Vendor and Purchaser agree that they shall not include any provision in the Purchase Agreement or any amendment to the Purchase Agreement or any other document (or indirectly do so through replacement of the Purchase Agreement) that derogates from, conflicts with or is inconsistent with the provisions of this Addendum, except where this Addendum expressly permits the parties to agree or consent to an alternative arrangement. The provisions of this Addendum prevail over any such provision.

**14. Time Periods, and How Notice Must Be Sent**

- (a) Any written notice required under this Addendum may be given personally or sent by email, fax, courier or registered mail to the Purchaser or the Vendor at the address/contact numbers identified on page 2 or replacement address/contact numbers as provided in paragraph (c) below. Notices may also be sent to the solicitor for each party if necessary contact information is provided, but notices in all events must be sent to the Purchaser and Vendor, as applicable.
- (b) Written notice given by one of the means identified in paragraph (a) is deemed to be given and received on the date of delivery or transmission, if given personally or sent by email or fax (or the next Business Day if the date of delivery or transmission is not a Business Day); on the second Business Day following the date of sending by courier; or on the fifth Business Day following the date of sending, if sent by registered mail. If a postal stoppage or interruption occurs, notices shall not be sent by registered mail, and any notice sent by registered mail within 5 Business Days prior to the commencement of the postal stoppage or interruption must be re-sent by another means in order to be effective. For purposes of this paragraph 14(b), Business Day includes Remembrance Day, if it falls on a day other than Saturday or Sunday, and Easter Monday.
- (c) If either party wishes to receive written notice under this Addendum at an address/contact number other than those identified on page 2, the party shall send written notice of the change of address/contact number to the other party.
- (d) Time periods within which or following which any act is to be done shall be calculated by excluding the day of delivery or transmission and including the day on which the period ends.
- (e) Time periods shall be calculated using calendar days including Business Days but subject to paragraphs (f), (g) and (h) below.
- (f) Where the time for making a claim under this Addendum expires on a day that is not a Business Day, the claim may be made on the next Business Day.
- (g) Prior notice periods that begin on a day that is not a Business Day shall begin on the next earlier Business Day, except that notices may be sent and/or received, on Remembrance Day, if it falls on a day other than Saturday or Sunday, or Easter Monday.
- (h) Every Critical Date must occur on a Business Day. If the Vendor sets a Critical Date that occurs on a date other than a Business Day, the Critical Date is deemed to be the next Business Day.

## **SCHEDULE A**

### **Types of Permitted Early Termination Conditions**

#### **(Section 2)**

#### **1. The Vendor of a condominium home is permitted to make the Purchase Agreement conditional as follows:**

(a) upon receipt of Approval from an Approving Authority for:

- (i) a change to the official plan, other governmental development plan or zoning by-law (including a minor variance);
- (ii) a consent to creation of a lot(s) or part-lot(s);
- (iii) a certificate of water potability or other measure relating to domestic water supply to the home;
- (iv) a certificate of approval of septic system or other measure relating to waste disposal from the home;
- (v) completion of hard services for the property or surrounding area (i.e., roads, rail crossings, water lines, sewage lines, other utilities);
- (vi) allocation of domestic water or storm or sanitary sewage capacity;
- (vii) easements or similar rights serving the property or surrounding area;
- (viii) site plan agreements, density agreements, shared facilities agreements or other development agreements with Approving Authorities or nearby landowners, and/or any development Approvals required from an Approving Authority; and/or
- (ix) site plans, plans, elevations and/or specifications under architectural controls imposed by an Approving Authority.

The above-noted conditions are for the benefit of both the Vendor and the Purchaser and cannot be waived by either party.

(b) upon:

- (i) receipt by the Vendor of confirmation that sales of condominium dwelling units have exceeded a specified threshold by a specified date;
- (ii) receipt by the Vendor of confirmation that financing for the project on terms satisfactory to the Vendor has been arranged by a specified date;
- (iii) receipt of Approval from an Approving Authority for a basement walkout; and/or
- (iv) confirmation by the Vendor that it is satisfied the Purchaser has the financial resources to complete the transaction.

The above-noted conditions are for the benefit of the Vendor and may be waived by the Vendor in its sole discretion.

#### **2. The following definitions apply in this Schedule:**

"Approval" means an approval, consent or permission (in final form not subject to appeal) from an Approving Authority and may include completion of necessary agreements (i.e., site plan agreement) to allow lawful access to and use and occupancy of the property for its intended residential purpose.

"Approving Authority" means a government (federal, provincial or municipal), governmental agency, Crown corporation, or quasi-governmental authority (a privately operated organization exercising authority delegated by legislation or a government).

#### **3. Each condition must:**

- (a) be set out separately;
- (b) be reasonably specific as to the type of Approval which is needed for the transaction; and
- (c) identify the Approving Authority by reference to the level of government and/or the identity of the governmental agency, Crown corporation or quasi-governmental authority.

#### **4. For greater certainty, the Vendor is not permitted to make the Purchase Agreement conditional upon:**

- (a) receipt of a building permit;
- (b) receipt of an occupancy permit; and/or
- (c) completion of the home.



**APPENDIX TO ADDENDUM  
TO AGREEMENT OF PURCHASE AND SALE  
EARLY TERMINATION CONDITIONS**

The Early Termination Conditions referred to in paragraph 2 (c) (ii) of the Tarion Addendum are as follows:

**CONDITIONS PERMITTED IN PARAGRAPH 1 (b) OF SCHEDULE "A" TO  
THE TARION ADDENDUM**

1. **Description of Early Termination Condition:**

This Agreement is conditional upon the Vendor entering into binding Agreements of Purchase and Sale for the sale of 80% of the dwelling units within the Condominium.

The date by which this Condition is to be satisfied is the 15<sup>th</sup> day of December, 2010.

2. **Description of Early Termination Condition:**

This Agreement is conditional upon the Vendor obtaining financing for the construction of the project on terms satisfaction to it in its discretion.

The date by which this Condition is to be satisfied is the 15<sup>th</sup> day of December, 2010.

3. **Description of Early Termination Condition:**

This Agreement is conditional upon the Vendor being satisfied, in its sole and absolute discretion, with the credit worthiness of the Purchaser. The Vendor shall have sixty (60) days from the date of acceptance of this Agreement by the Vendor to satisfy itself with respect to such credit worthiness. The Purchaser covenants and agrees to provide all requisite information and materials including proof respecting income and source of funds or evidence of a satisfactory mortgage approval signed by a lending institution or other mortgagee acceptable to the Vendor, confirming that the said lending institution or acceptable mortgagee will be advancing funds to the Purchaser sufficient to pay the balance due on the Title Transfer Date, as the Vendor may require to determine the Purchaser's credit worthiness.

The date by which this Condition is to be satisfied is the 27 day of March, 2010.

This is Exhibit "B" referred to in the Affidavit of  
Ryan Cyrankiewicz sworn October 14, 2015

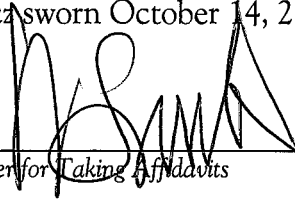

---

Commissioner for Taking Affidavits



**AMENDMENT TO THE  
AGREEMENT OF PURCHASE AND SALE**

**BETWEEN:** 144 PARK LTD. (the "Vendor") and Laurie and Ryan Cyrankiewicz (the "Purchaser")  
Unit 04, Level 14 (the "Unit")

It is hereby understood and agreed between the Vendor and the Purchaser that the following change(s) shall be made to the above-mentioned Agreement of Purchase and Sale, and except for such change(s) noted below, all other terms and conditions of the Agreement shall remain as stated therein, and time shall continue to be of the essence.

**DELETE:**

LEVEL #: 14  
UNIT #: 04  
SUITE #: 1404  
MODEL: S1032

**INSERT:**

LEVEL #: 15  
UNIT #: 04  
SUITE #: 1504  
MODEL: S1032

DATED at Kitchener, this 15<sup>th</sup> day of June, 2010.

IN WITNESS whereof the parties hereto have affixed their hands and seals.

**SIGNED, SEALED AND DELIVERED**  
in the presence of

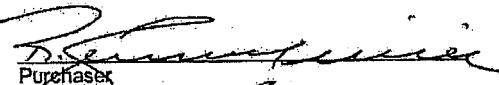
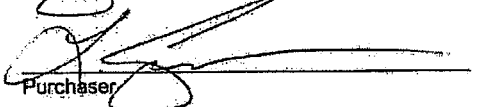
  
Purchaser  
  
Purchaser

**144 PARK LTD.**

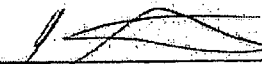
Per:   
Authorized Signing Officer  
I have the authority to bind the Corporation.

This is Exhibit "C" referred to in the Affidavit of  
Ryan Cyrankiewicz sworn October 14, 2015

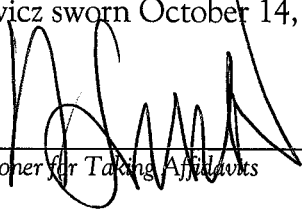

---

Commissioner for Taking Affidavits



ARCH DRAWING #: A207

Laurie & Ryan Cyrankiewicz  
 3-6 Sims Estate Place  
 Kitchener, ON  
 N2A 0A5  
 H: 519.654.6362  
 E: ryan@nexcell.ca

LEVEL, UNIT: 15.4  
 TYPE: 2 Bedrm + Den  
 MODEL: S1032  
 VERSION: A

	Type	Standard	Upgrade	Retail Price
Living / Dining / Den	Flooring	5/8" x 6"	GENERATIONS, Red Oak Graphite	\$810.00
	Flooring	5/8" x 6"	GENERATIONS, Red Oak Graphite	\$5,265.00
	Flooring	5/8" x 6"	GENERATIONS, Red Oak Graphite	\$1,520.00
	Cabinetry		TGP 760 Maple - Espresso	\$1,376.00
	Light Valance	INSTALL: Light Valance	TGP 760 Maple - Espresso	\$416.00
	Single Pole Switch	Wire puck lighting into a separate switch next to kitchen light		\$264.00
	Puck Lighting	INSTALL: 1 set (3) of Chrome Puck light underneath kitchen upper cabinets on the fridge wall - UCP-LBD3-CH		\$240.00
	Countertop		Moon	\$1,374.00
	Countertop Edge		Double Edge, Level 1, #12	\$916.00
	Hardware	12895		
	Granite 4" Backsplash	Deluxe 4" Backsplash		
	Backsplash		Regal Linear Mosaic Polished- Irregular 12x12 - Grey	\$1,280.00
	Kitchen Faucet		Kohler-Bellara Pull-down Kitchen Sink Faucet	\$320.00
	Sink		Siella-ST404	\$900.00
Kitchen	Bulkhead Above Peninsula	INSTALL: A bulkhead above peninsula to accommodate for future pendant light		\$3,200.00
	Installation / Wiring / Electrical	Installation, wiring and electrical for Capped Ceiling Outlet above peninsula		\$320.00
	Single Pole Switch	Wire Capped Ceiling Outlet above peninsula into a separate switch next to kitchen light		\$284.00
	Capped ceiling Outlet	INSTALL: 2 Capped Ceiling Outlet above peninsula- Space Capped Outlet out EVENLY		\$80.00
	APPLIANCES	Whirlpool Appliance package #1		\$2,996.00
	Refrigerator		Whirlpool 30" 19.6 cu.ft. French Door Refrigerator with Exterior Water Dispenser WRF640SEYM	\$1,170.00
	Stove		Whirlpool 30" Self-Cleaning Slide In Electric Range - CY97LXUS	Pkg Price
	Microwave/Hood Fan	Whirlpool 1.7 cu.ft. Microwave Range Hood Combination - YWMH31017AS, Stainless		Pkg Price
	Dishwasher		Whirlpool Under Counter Dishwasher Stainless Handle - WDT710PATM	Pkg Price
	Appliance Notes			
Water Line	INSTALL WATERLINE FOR FRIDGE		\$30.00	
Laundry Room	Flooring		GENERATIONS, Red Oak Graphite	\$375.00
	Washer	WHIRLPOOL Front Load Washer, WFW9050XW-White		
	Dryer	WHIRLPOOL Front Load Dryer, YWED9050XW-White		
	Extra			
	Extra			
Main Bathroom	Flooring	INSTALL: Horizontally Stacked	Tropical Grass, 12x24 - Modia	\$308.00
	Tub Wall Tile	Fabrio, 10x20 - White	INSTALL: Standard Stacked Horizontally	
	Cabinetry		Aluminum Edge (AEM) - Nero	\$82.00
	Metal Legs on Vanity	INSTALL: Metal Legs in lieu of Toe kick on vanity		\$96.00
	Countertop		Moon	\$1,024.00
	Countertop Edge	3/4" Polished		
	Sink		1 Rectangular Sink	Pkg Price
	Hardware	12895		
	Faucet		Kohler-Refinia Widespread Bathroom Sink Faucet	\$296.00
	Tub Faucet	Kohler-Cornelia Bath and Shower Faucet Trim		
Extra				
Extra				



SUITE # 1504

9-May-14

Laurie & Ryan Cyrankiewicz  
 3-6 Sims Estate Place  
 Kitchener, ON  
 N2A 0A5  
 H: 519.654.6362  
 E: ryanc@nexcell.ca

ARCH DRAWING #: A207

LEVEL, UNIT: 15.4  
 TYPE: 2 Bedrm + Den  
 MODEL: S1032  
 VERSION: A

	Type	Standard	Upgrades	Retail Price	
Master Bedroom	Flooring	5/8" x 6"	GENERATIONS, Red Oak Graphite	\$1,968.00	
Master Bath	Flooring		INSTALL: Horizontally Stacked Tropical Grass, 12x24 - White	\$512.00	
	Tub Wall Tile		INSTALL: Horizontally Stacked Tropical Grass, 12x24 - White	\$720.00	
	Shower Wall Tile		INSTALL: Horizontally Stacked Tropical Grass, 12x24 - White	\$1,104.00	
	Shower Floor Tile		Quebec - Unglazed Mosaic 2x2- Arctic White		
	Cabinetry		Aluminum Edge (AEM) - Grigio	\$82.00	
	Metal Legs on Vanity		INSTALL / Metal Legs in lieu of Toe kick on vanity	\$76.00	
	Countertop		Lakes	\$1,094.00	
	Countertop Edge		3/4" Polished		
	Sink		1 Rectangular Sink	Plg Price	
	Hardware		12895		
	Faucet		Kohler-Refinia Widespread Bathroom Sink Faucet	\$296.00	
	Tub Faucet		Kohler-Consais Bath and Shower Faucet Trim		
	Shower Faucet		Kohler-Consais Bath and Shower Faucet Trim		
Extra					
Master Bedroom	Flooring	5/8" x 6"	GENERATIONS, Red Oak Graphite	\$2,665.00	
Baseboard (Trim)		Standard			
Crown Molding		N/A			
Gas Fireplace			Custom Design Gas Fireplace	\$10,659.00	
Electric Fireplace			N/A		
Gas Line			Gas Line For Fireplace	\$5,900.00	
Additional Building			INSTALL: Additional Blocking above fireplace wall for mounting of a fitness TV	\$400.00	
Cable Outlet			INSTALL: 1 Cable Outlet above fireplace - Refer to Custom Fireplace Design for location	\$552.00	
Electrical Outlet			INSTALL: 1 Duplex Receptacle above fireplace - Refer to Custom Fireplace Design for location	\$284.00	
Single Pole Switch			INSTALL: 1 Single Pole Switch to turn on fireplace	\$284.00	
Notes	INSTALL / WATERLINE for refrigerator				
Notes	INSERT: The vendor agrees to provide a credit in the amount of Two Thousand Five Hundred CND Dollars (\$2500) towards upgrades				
				Subtotal	\$50,887.00
				Tax Amount	\$6,615.31
				Total	\$57,502.31
				Adjustment(s)	\$2,900.00
				Total Due Amount After Tax	\$54,602.31
				Deposit Required	\$27,501.00
				Final Balance	\$27,501.31
* All cheques to be made payable to Harris Sheffer LLP, in Trust.					
I hereby agree that I have selected the above noted colours, materials and finishes for my unit at 144 Park in Waterloo from the Vendor's standard and/or upgrade samples. All selections are final. I further agree to pay in full for such selections/upgrades, failing which it is agreed that any or all selections may be cancelled and replaced with finishes selected by the Vendor. A 50% deposit on all upgrade selection is required. I acknowledge and agree that natural materials, including granite, wood, marble, etc., are subject to natural variations in colour and grain. Ceramic tile and broadband are subject to pattern, shade and colour variations. The Vendor reserves the right to cancel or reject any or all upgrades, or selections made by the Purchaser, provided that any payments made by the Purchaser for the upgrades, or selections, are returned in full upon cancellation. In the event that any or all of the upgrades are not installed or provided as specified, the Purchaser's sole recourse shall be the return of the monies paid for the particular incorrectly supplied or installed upgrades or selections. The Vendor shall not be responsible or obligated to replace the upgrade, or to install it in a different location.					
Decor Consultant		Date:			
Purchaser		Date:			

This is Exhibit "D" referred to in the Affidavit of  
Ryan Cyrankiewicz sworn October 14, 2015

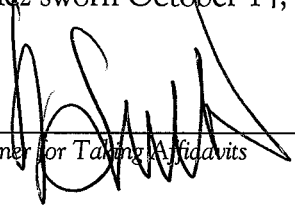
A handwritten signature in black ink, appearing to be 'H. Smith', written over a horizontal line.

*Commissioner for Taking Affidavits*

**INTERIM STATEMENT OF ADJUSTMENTS**

RE: 144 Park Ltd. sale to Laurie Cyrankiewicz and Ryan Cyrankiewicz  
Unit 4, Level 15, Unit 2, Level 3, Unit 3, Level 3, Unit 41, Level 3, WSCP TBR  
Suite 1504, 144 Park Street, Waterloo, Ontario N2L 0B6

Tarion Builder Registration Number: 39278  
Tarion Unit Enrolment Number: H1816762

Closing Date: September 30, 2014

PURCHASE PRICE inclusive of HST (where applicable)		\$ 383,600.00
UPGRADE CHARGES inclusive of HST		\$ 55,002.31
TOTAL DEPOSITS	\$ 57,540.00	
UPGRADE CHARGES PAID	\$ 27,501.00	
UNADJUSTED BALANCE DUE ON THE UNIT TRANSFER DATE	\$ 326,060.00	
BALANCE DUE ON CLOSING paid by certified cheque to <i>Harris, Sheaffer LLP, In Trust</i> E. & O.E.	\$27,501.31	
	<u>\$438,602.31</u>	<u>\$438,602.31</u>

NOTE: In addition to the unadjusted balance due on closing, if any, the Purchaser must deliver the following cheques:

- (i) Certified Cheque payable to Harris, Sheaffer LLP in the sum of \$53.50 being the pro-rated amount of monthly Occupancy Fee from September 30, 2014 to the day prior to the first day of the following month.
- (ii) 5 post-dated cheques each dated the 1st of the month, in the sum of \$1,605.14 commencing October 1, 2014 payable to 144 Park Ltd.

In accordance with the Condominium Act, 1998 and the Agreement of Purchase and Sale, the Occupancy Fee comprises the following:

Estimated Total Common Expenses:	\$551.95
Estimated Realty Taxes:	\$200.00
Interest on the Unadjusted Balance Due on the Unit Transfer Date at the prescribed rate of 3.1400%	\$853.19
TOTAL	<u>\$1,605.14</u>

NOTE 1: All calculations with respect to Goods and Services Tax or the Harmonized Sales Tax (if applicable), will be addressed on the Final Statement of Adjustments.  
E. & O. E.

NOTE 2:

*Please note it is the policy of this firm that funds being delivered to us by certified cheque for a closing must be from the purchaser's solicitor's trust account and not directly from a purchaser or any other person. No bank drafts are permitted.*

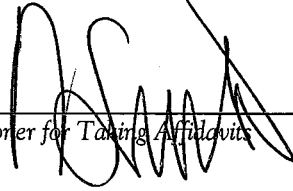

This is Exhibit "E" referred to in the Affidavit of  
Ryan Cyrankiewicz sworn October 14, 2015

A handwritten signature in black ink, appearing to be "ASW", written over a horizontal line.

*Commissioner for Taking Affidavits*



HST # 863147658

- London: 4045 Blaine Rd., N6L 1R5 Ph: (519) 852-9029 Fax: (519) 852-0861
- Simla: 1382 Lambton Mall Rd., Unit 17, N7S 5A1 Ph: (519) 542-8212 Fax: (519) 542-9702
- St. Thomas: 468-470 Talbot Street, N5P 1C2 Ph: (519) 631-0401 Fax: (519) 631-0444
- Stratford: 1020 Ontario Street, N5A 6Z3 Ph: (519) 271-5004 Fax: (519) 271-5011
- Waterloo: 283 Northfield East, Unit 10 N2J 4G8 Ph: (519) 888-0401 Fax: (519) 888-7920

**Agreement for the Supply of Goods and / or Services** Invoice # 09853

Buyer Information: PO: BJO - CYRANK Date: APRIL 29th 2015

Name: RYAN CYRANKIEWICZ

Address: 1504 - 144 PARK STREET City: WATERLOO Postal Code: N2L 1Y5

Home Ph: NIKI 519-500-1050 Business Ph: \_\_\_\_\_ Ext: \_\_\_\_\_  Mr.  Ms.

E-mail: NIKIALEXTON@GMAIL.COM Cell:  Mr. \_\_\_\_\_  Ms.: \_\_\_\_\_

**Builder Information:**

Builder: \_\_\_\_\_ Closing Date: \_\_\_\_\_

Subdivision: \_\_\_\_\_ Lot#: \_\_\_\_\_ Street: \_\_\_\_\_

- Terms And Conditions:**
1. This agreement is binding only upon execution by the Buyer(s) and an authorized representative of the Seller.
  2. This Seller agrees to supply goods and / or services as noted on this Agreement and as indicated on the drawings and specifications attached hereto and initialled by both parties.
  3. Any amendments will require a written change order.
  4. The Buyer is responsible for the accuracy of all dimensions supplied by the Buyer or authorized representative.
  5. The terms and conditions on the back of this document are Included In this Agreement between the Seller and Buyer.
  6. Upon full payment of contract price, the Buyer is entitled to the warranty provided by the manufacturer.
  7. Service charge of 2.5% per month will apply to all overdue accounts
  8. I have read and understand the terms and conditions on the back of this contract: \_\_\_\_\_ (initial)

**Buyer Responsibility:**

... Remove Existing Cabinets    ... Move Appliances    ... Plumbing    ... Electrical    ... Disposal of

... Disposal of Existing cabinets    ... Prepare Floor    ... Prepare Walls    ... Stove Venting    Cabinet Packaging

Pricing:		Terms of Payment:	
Purchase Price of Goods and Services	6,841.90	Payment Upon Buyer's Acceptance <i>RETAINED</i>	2,000.00 <i>PD</i>
HST	889.45	Payment Upon Delivery/Pick-up of cabinets <i>BUYER'S ACCEPTANCE</i>	1,800.00
Total Purchase Price	7,731.35	Payment Upon Substantial Completion <i>DELIVERY</i>	3,400.00
		<i>PAYMENT UPON SUBSTANTIAL COMPLETION</i>	531.35

**Builder Pricing Information:**

Builder Allowance	Over Allowance
HST	HST
TOTAL	TOTAL

Bill over allowance to the Builder                       Bill over allowance to the Buyer

Buyer Signature: \_\_\_\_\_ Casey's Creative Kitchens Representative: \_\_\_\_\_



Niki & Ryan Cryankiewicz  
144 Park  
Unit 1501  
Waterloo, On  
519-500-1050

2015-126 layout 1  
Proposal Page  
Designed: 07/07/2015 11:11:58 AM  
Notes:



50 Goebel Ave, Unit 11  
Cambridge, Ontario  
PH: 519-651-2555  
FAX: 519-651-2513  
spaceageshelving.com  
closets@spaceageshelving.com

**master**

**\$2604.68**

Room Options: MasterSuite Options: Hardware Finish: Bronze, Shelf Bracket Finish: Bronze, Sidelines Options: Hardware Finish: Bronze, Handle Style: Arched, Finish: Chocolate Pear, Door Style: Solid Wood, Box Type: Birch  
Storage Lengths: Shelf Length: 37.651 ft, Hang Length: 4.82 ft, Shoe Length: 0 ft

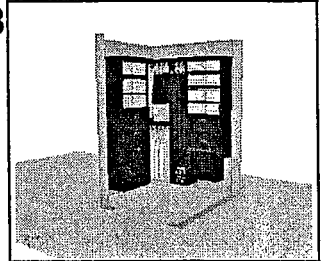

**Front hall**

**\$595.23**

Room Options: MasterSuite Options: Hardware Finish: Bronze, Shelf Bracket Finish: Bronze, Finish: Chocolate Pear  
Storage Lengths: Shelf Length: 16.958 ft, Hang Length: 4.625 ft, Shoe Length: 0 ft

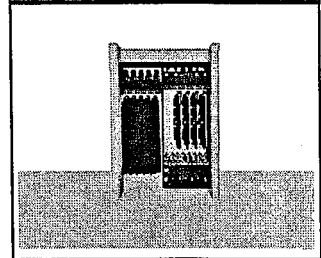

**Total:\$3199.91**

**Deposit: \$0.00**

**Balance Due:\$3199.91**

**Notes: Quote is valid for 30 days.**

**Balance Due price is for material and install, and does not include HST.**

**HST will be added to your invoice total.**

**50% deposit is required when placing your order, balance is due on install date.**

**X** \_\_\_\_\_

**X** \_\_\_\_\_

**If multiple layouts have been sent to you, we will require you to sign and date at the X's the layout you are choosing, and email this back as your confirmation of the order.**



**Niki & Ryan Cryankiewicz**  
144 Park  
Unit 1501  
Waterloo, On  
519-500-1050

**2015-126 layout 1**  
**master Default 3D View**  
**Designed: 07/07/2015 11:11:58 AM**  
**Price: \$3,199.91**  
**Deposit: \$0.00**  
**Balance Due at Installation:**  
**Approved: Jamie**



50 Goebel Ave, Unit 11  
Cambridge, Ontario  
PH: 519-651-2555  
FAX: 519-651-2513  
spaceageshelving.com  
closets@spaceageshelving.com

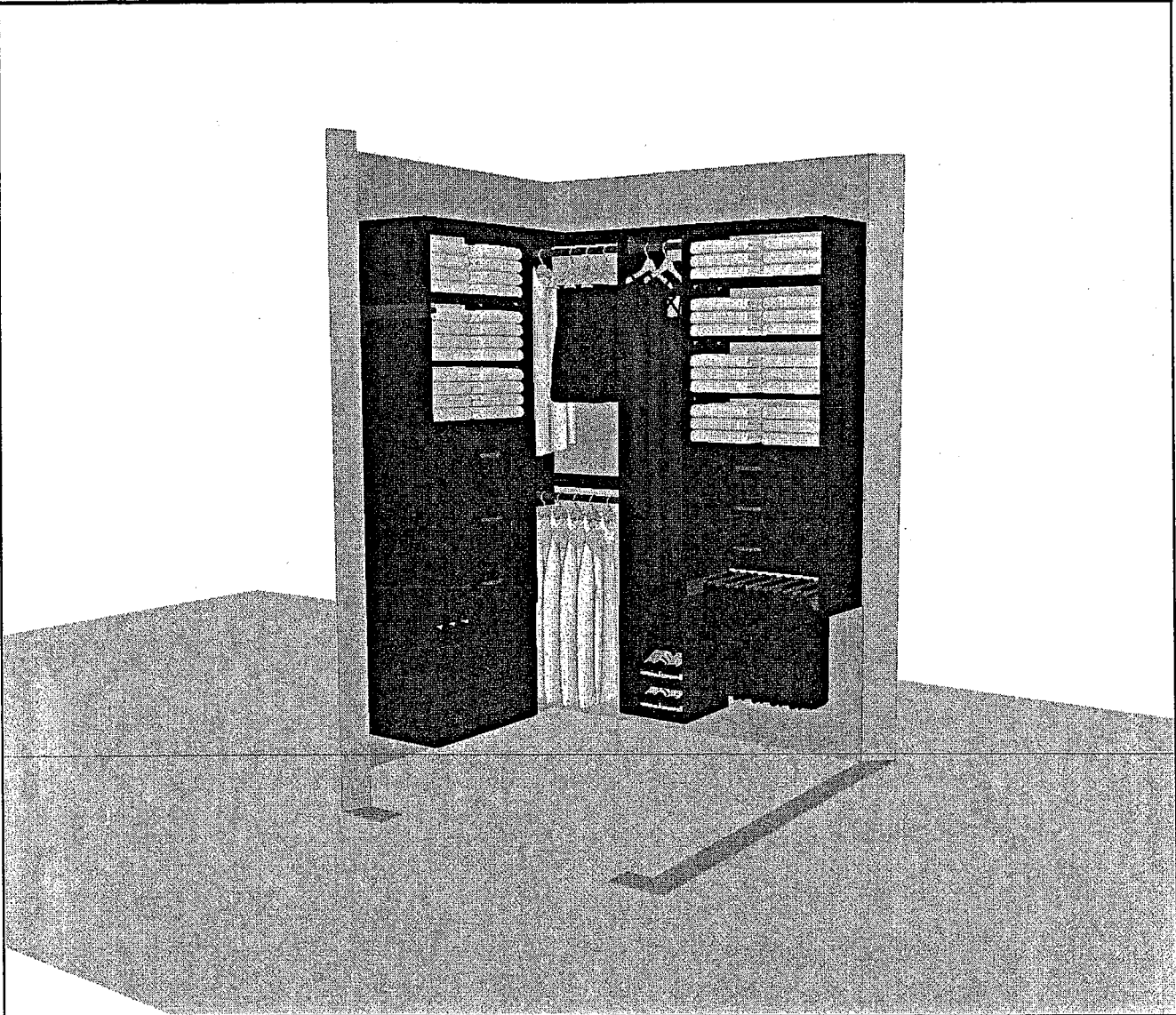

LiveStorage software under license from CHI-LLC®  
Version 6.0



**Niki & Ryan Cryankiewicz**  
144 Park  
Unit 1501  
Waterloo, On  
519-500-1050

**2015-126 layout 1**  
**master 3D View 1**  
**Designed: 07/07/2015 11:11:58 AM**  
**Price: \$3,199.91**  
**Deposit: \$0.00**  
**Balance Due at Installation:**  
**Approved: Jamie**



50 Goebel Ave, Unit 11  
Cambridge, Ontario  
PH: 519-651-2555  
FAX: 519-651-2513  
spaceageshelving.com  
closets@spaceageshelving.com

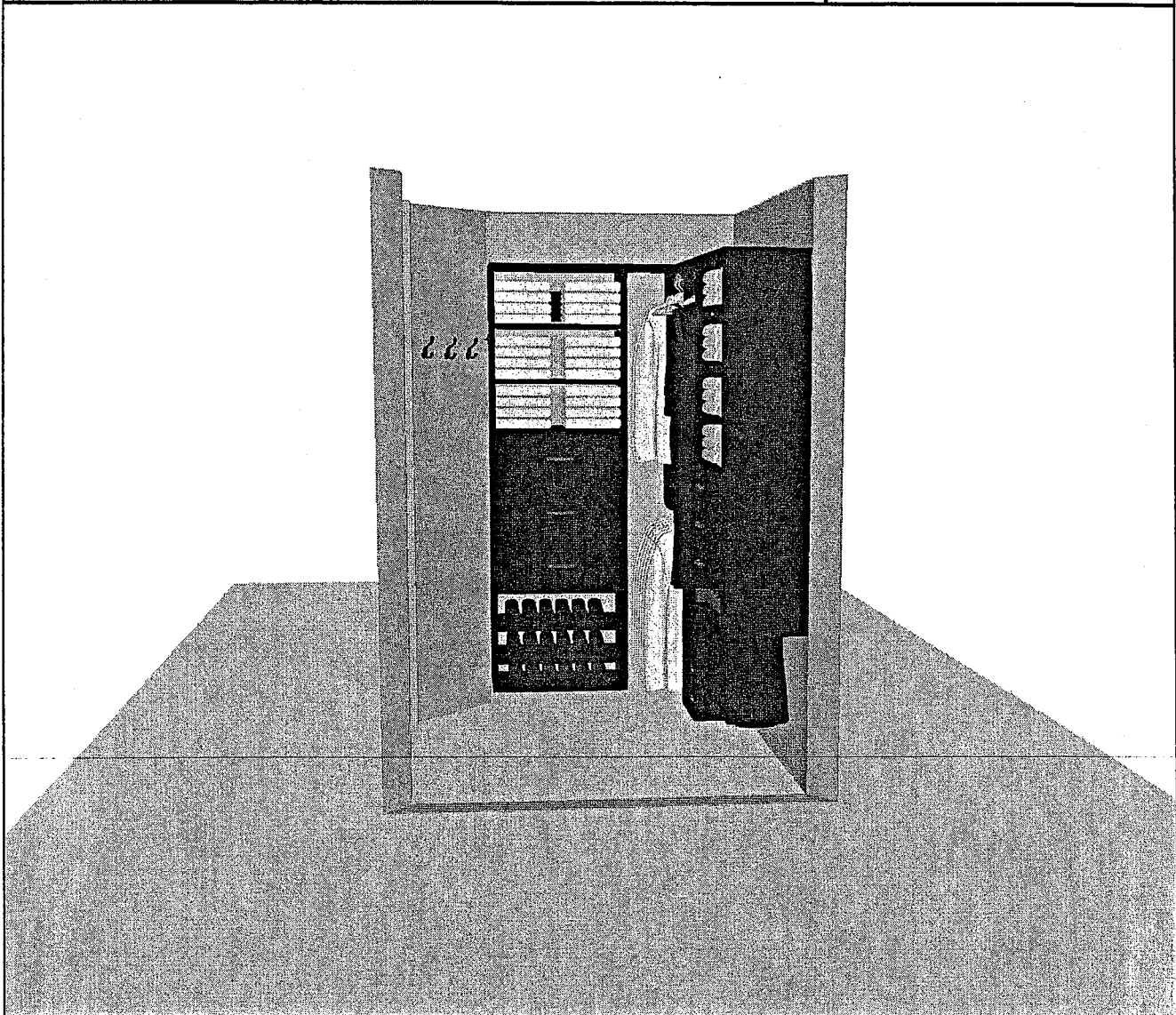

LiveStorage software under license from CHI-LLC®  
Version 6.0



Niki & Ryan Cryankiewicz  
144 Park  
Unit 1501  
Waterloo, On  
519-500-1050

2015-126 layout 1  
master Plan Page 1  
Designed: 07/07/2015 11:11:58 AM  
Price: \$3,199.91  
Deposit: \$0.00  
Balance Due at Installation:  
Approved: Jamie



50 Goebel Ave, Unit 11  
Cambridge, Ontario  
PH: 519-651-2555  
FAX: 519-651-2513  
spaceageshelving.com  
closets@spaceageshelving.com

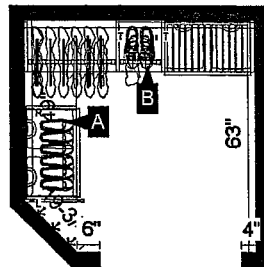

On angle wall, the 3 hooks  
Brushed, will be mounted on a  
Chocolate pear board, not  
shown in drawing.

Chocolate pear  
14" deep hang  
system. Solid  
wood drawer  
fronts, birch boxes  
with soft close  
glides, and oil rub  
bronze bar  
handles. Valet and  
rod are oil rub  
bronze. Pull out  
pant rack.



**Niki & Ryan Cryankiewicz**  
**144 Park**  
**Unit 1501**  
**Waterloo, On**  
**519-500-1050**

**2015-126 layout 1**  
**master Plan Page 2**  
**Designed: 07/07/2015 11:11:58 AM**  
**Price: \$3,199.91**  
**Deposit: \$0.00**  
**Balance Due at Installation:**  
**Approved: Jamie**



**50 Goebel Ave, Unit 11**  
**Cambridge, Ontario**  
**PH: 519-651-2555**  
**FAX: 519-651-2513**  
**spaceageshelving.com**  
**closets@spaceageshelving.com**

Wall Elevation **A**

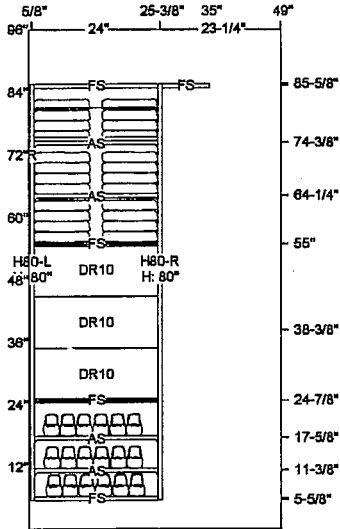

Wall Elevation **B**

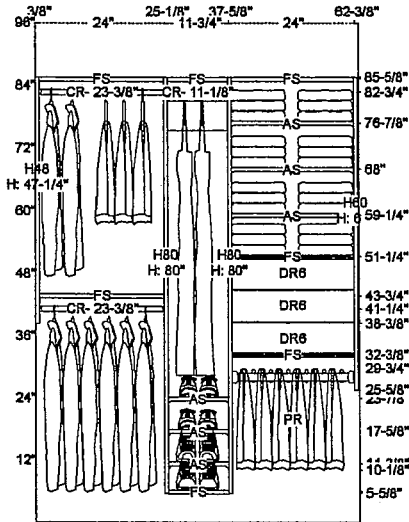



**Niki & Ryan Cryankiewicz**  
144 Park  
Unit 1501  
Waterloo, On  
519-500-1050

**2015-126 layout 1**  
**Front hall Default 3D View**  
**Designed: 07/07/2015 11:11:58 AM**  
**Price: \$3,199.91**  
**Deposit: \$0.00**  
**Balance Due at Installation:**  
**Approved: Jamie**



50 Goebel Ave, Unit 11  
Cambridge, Ontario  
PH: 519-651-2555  
FAX: 519-651-2513  
spaceageshelving.com  
closets@spaceageshelving.com

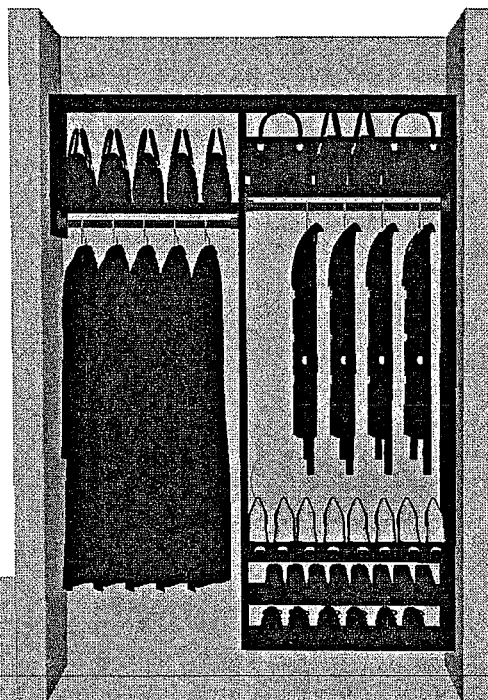

LiveStorage software under license from CHI-LLC®  
Version 6.0



**LiveStorage**

**Niki & Ryan Cryankiewicz**  
144 Park  
Unit 1501  
Waterloo, On  
519-500-1050

**2015-126 layout 1**  
**Front hall Plan Page 1**  
**Designed: 07/07/2015 11:11:58 AM**  
**Price: \$3,199.91**  
**Deposit: \$0.00**  
**Balance Due at Installation:**  
**Approved: Jamie**



50 Goebel Ave, Unit 11  
Cambridge, Ontario  
PH: 519-651-2555  
FAX: 519-651-2513  
spaceageshelving.com  
closets@spaceageshelving.com

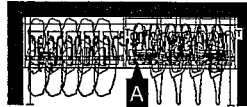

Chocolate pear  
14" deep hang  
system, Oil Rub  
Bronze rods.

LiveStorage software under license from CHI-LLC®  
Version 6.0



**Niki & Ryan Cryankiewicz**  
144 Park  
Unit 1501  
Waterloo, On  
519-500-1050

**2015-126 layout 1**  
**Front hall Plan Page 2**  
**Designed: 07/07/2015 11:11:58 AM**  
**Price: \$3,199.91**  
**Deposit: \$0.00**  
**Balance Due at Installation:**  
**Approved: Jamie**



50 Goebel Ave, Unit 11  
Cambridge, Ontario  
PH: 519-651-2555  
FAX: 519-651-2513  
spaceageshelving.com  
closets@spaceageshelving.com

Wall Elevation **A**

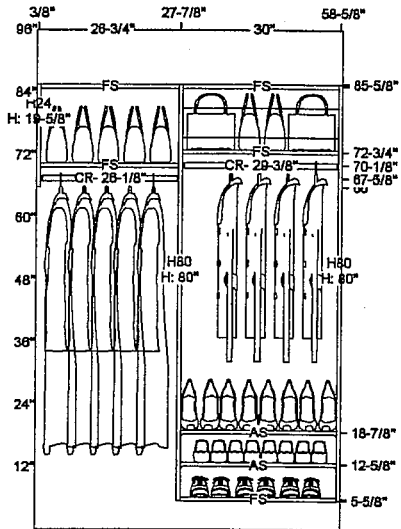

This is Exhibit "F" referred to in the Affidavit of  
Ryan Cyrankiewicz sworn October 14, 2015

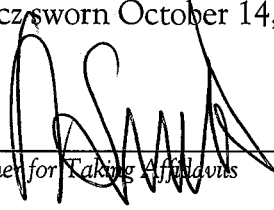
A handwritten signature in black ink, appearing to be "D. Smith", written over a horizontal line.

Commissioner for Taking Affidavits

OCCUPANCY ACKNOWLEDGMENT

TO: 144 Park Ltd. (the "Vendor")  
AND TO: Harris, Sheaffer LLP  
its solicitors herein  
RE: 144 Park Ltd. sale to Laurie Cyrankiewicz and Ryan Cyrankiewicz (the "Purchaser")  
Unit 4, Level 15, Unit 2, Level 3, Unit 3, Level 3, Unit 41, Level 3, WSCP TER (the  
"Unit")  
Suite 1504, 144 Park Street, Waterloo, Ontario N2L 0B6  
Agreement of Purchase and Sale accepted January 27, 2010 ("the Agreement")

WHEREAS the Purchaser and the Vendor did execute the Agreement;

AND WHEREAS the Agreement includes Paragraph 23 and Schedule C thereto, being the terms of occupancy of the Unit until the Unit Transfer Date/Title Transfer Date;

NOW THEREFORE THIS AGREEMENT WITNESSETH THAT in consideration of the Vendor allowing the Purchaser to occupy the Unit pursuant of the Agreement, and for other good and valuable consideration, the Vendor and the Purchaser covenant and agree with each other as follows:

1. The undersigned, being the Purchaser of the above noted property, hereby agrees to occupy the Unit in accordance with the terms of the occupancy as set out in the Agreement, and acknowledges and agrees that the licence to occupy is not a tenancy within the meaning of the Residential Tenancies Act.
2. The Occupancy Fee as defined in Paragraph 23 and Schedule C of the Agreement is \$1,605.14 per month.
3. Any notice required to be given to the Vendor's solicitors shall be to Harris, Sheaffer LLP, 4100 Yonge Street Suite 610, Toronto, Ontario M2P 2B5 to the attention of Mark Karoly.
4. The unadjusted balance due on the Closing Date required to be paid by the Purchaser to the Vendor, by certified cheque payable to Harris, Sheaffer LLP, In Trust, on the Closing Date is \$27,501.31 in accordance with Paragraph 1, and its subparagraphs, of the Agreement and in accordance with the Interim Statement of Adjustments.
5. The transfer of possession of the Unit to the Purchaser shall not be deemed or considered in any way a release, abandonment or waiver of any of the rights of either the Purchaser or the Vendor with respect to the provisions of the Agreement and all schedules thereto.
6. The undersigned further acknowledges that the undersigned shall be allowed to remain in occupancy of the subject premises so long as the terms of the occupancy and the Agreement are not in default, and that should the undersigned fail to rectify and default within 5 days of notice thereof, the undersigned agrees to deliver up vacant possession of the Unit immediately.
7. The undersigned further authorize the inspectors of any mortgagee and the building inspectors of the applicable municipality, accompanied by a representative of 144 Park Ltd., to enter the above noted property at all reasonable hours and upon reasonable prior notice.
8. The undersigned further authorize 144 Park Ltd., its employees and subcontractors, to enter the above noted property at all reasonable hours and upon reasonable prior notice, for the purpose of rectifying deficiencies or for any purpose for which the Condominium Corporation would be permitted entry under the Condominium Act, 1998.

Dated at the City of Waterloo, in the Province of Ontario, this 14th day of August 2014.

  
Witness: (as to all signatures, if applicable)  
Karen Johnson

  
Ryan Cyrankiewicz

OCCUPANCY ACKNOWLEDGMENT

TO: 144 Park Ltd. (the "Vendor")  
AND TO: Harris, Sheaffer LLP  
its solicitors herein  
RE: 144 Park Ltd. sale to Laurie Cyrankiewicz and Ryan Cyrankiewicz (the "Purchaser")  
Unit 4, Level 15, Unit 2, Level 3, Unit 3, Level 3, Unit 41, Level 3, WSCP TBR (the  
"Unit")  
Suite 1504, 144 Park Street, Waterloo, Ontario N2L 0B6  
Agreement of Purchase and Sale accepted January 27, 2010 ("the Agreement")

WHEREAS the Purchaser and the Vendor did execute the Agreement;

AND WHEREAS the Agreement includes Paragraph 23 and Schedule C thereto, being the terms of occupancy of the Unit until the Unit Transfer Date/Title Transfer Date;

NOW THEREFORE THIS AGREEMENT WITNESSETH THAT in consideration of the Vendor allowing the Purchaser to occupy the Unit pursuant to the Agreement, and for other good and valuable consideration, the Vendor and the Purchaser covenant and agree with each other as follows:

1. The undersigned, being the Purchaser of the above noted property, hereby agrees to occupy the Unit in accordance with the terms of the occupancy as set out in the Agreement, and acknowledges and agrees that the licence to occupy is not a tenancy within the meaning of the Residential Tenancies Act.
2. The Occupancy Fee as defined in Paragraph 23 and Schedule C of the Agreement is \$1,605.14 per month.
3. Any notice required to be given to the Vendor's solicitors shall be to Harris, Sheaffer LLP, 4100 Yonge Street Suite 610, Toronto, Ontario M2P 2B5 to the attention of Mark Karoly.
4. The unadjusted balance due on the Closing Date required to be paid by the Purchaser to the Vendor, by certified cheque payable to Harris, Sheaffer LLP, in Trust, on the Closing Date is \$27,501.51 in accordance with Paragraph 1, and its subparagraphs, of the Agreement and in accordance with the Interim Statement of Adjustments.
5. The transfer of possession of the Unit to the Purchaser shall not be deemed or considered in any way a release, abandonment or waiver of any of the rights of either the Purchaser or the Vendor with respect to the provisions of the Agreement and all schedules thereto.
6. The undersigned further acknowledges that the undersigned shall be allowed to remain in occupancy of the subject premises so long as the terms of the occupancy and the Agreement are not in default; and that should the undersigned fail to rectify and default within 5 days of notice thereof, the undersigned agrees to deliver up vacant possession of the Unit immediately.
7. The undersigned further authorize the inspectors of any mortgagee and the building inspectors of the applicable municipality, accompanied by a representative of 144 Park Ltd., to enter the above noted property at all reasonable hours and upon reasonable prior notice.
8. The undersigned further authorize 144 Park Ltd., its employees and subcontractors, to enter the above noted property at all reasonable hours and upon reasonable prior notice, for the purpose of rectifying deficiencies or for any purpose for which the Condominium Corporation would be permitted entry under the Condominium Act, 1998.

Dated at the City of Vernon, BC, in the Province of Ontario, this 6th day of October 2014.

[Signature]  
Witness: (see to all signatures, if applicable)  
[Signature]  
Laurie Cyrankiewicz

This is Exhibit "G" referred to in the Affidavit of  
Ryan Cyrankiewicz sworn October 14, 2015

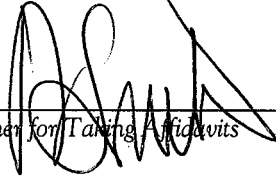

---

Commissioner for Taking Affidavits

**DIRECTION RE TITLE**

TO: 144 Park Ltd.  
AND TO: Harris, Sheaffer LLP  
its solicitors herein  
RE: 144 Park Ltd. sale to Laurie Cyrankiewicz and Ryan Cyrankiewicz  
Unit 4, Level 15, Unit 2, Level 3, Unit 3, Level 3, Unit 41, Level 3, WSCP TBR  
Suite 1504, 144 Park Street, Waterloo, Ontario N2L 0B6

YOU ARE HEREBY authorized and directed to engross the Transfer/Deed of Land in the above noted transaction as follows:

Transferee: (Name(s)) Laurie Ray Cyrankiewicz  
Social Insurance Number (Required Information) 607 047 798  
Date of Birth (yyyy/mm/dd) 1958/01/12

RELATIONSHIP: \_\_\_\_\_

Spousal Status: Not a Spouse

Address for Service: 320 Rexy Place  
Vernon, BC V1H 1V6

and for so doing, let this be your good, sufficient and irrevocable authority and indemnity.

A facsimile or emailed copy of this document (including the Assignment set out below) shall, for all purposes, be treated and enforced in the same manner as an originally executed copy.

**ASSIGNMENT**

In the event the Transferee(s) named in the above Direction is/are not the same person(s) as the party(ies) named as Purchaser in the Agreement of Purchase and Sale, then the above Direction shall be deemed to operate as an Assignment of the Agreement of Purchase and Sale to the person(s) named above as Transferee(s) and such Transferee(s) signifies its/their acceptance of such assignment and its/their covenant to the Vendor to be bound by the terms of the Agreement of Purchase and Sale by signing below. In such event, the Purchaser(s) as set out below acknowledge that this Assignment shall not relieve the Purchaser(s) of any liability or obligations pursuant to the terms of the Agreement of Purchase and Sale.

WITNESS: O. Albrecht

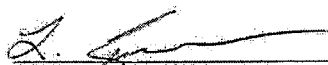
  
Transferee: Laurie Cyrankiewicz

(To be signed if Transferee differs from the Purchaser named in the Agreement of Purchase and Sale.)

**NOTES:**

Where the Transferee(s) differ(s) from the party(ies) named as Purchaser(s) in the Agreement of Purchase and Sale, all other closing documents must be signed by the Purchaser(s) named in the Agreement of Purchase and Sale and by the Transferee(s).

Dated at the City of Waterloo, in the Province of Ontario, this 6th day of October, 2014.

  
Witness: (see to all signatures, if applicable)

  
Laurie Cyrankiewicz

  
(at Waterloo, ON on Oct 8, 2014)

  
Ryan Cyrankiewicz

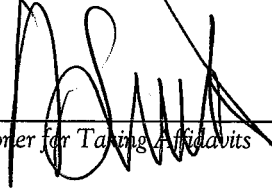

This is Exhibit "H" referred to in the Affidavit of  
Ryan Cyrankiewicz sworn October 14, 2015

A handwritten signature in black ink, appearing to be "M. J. ...", written over a horizontal line.

Commissioner for Taking Affidavits

# HARRIS, SHEAFFER LLP

BARRISTERS & SOLICITORS

YONGE CORPORATE CENTRE  
4100 YONGE STREET, SUITE 610, TORONTO, ONTARIO M2P 2B5  
TELEPHONE (416) 250-5800 / FACSIMILE (416) 250-5300

June 16, 2015  
File No.: 090328  
Contact: Karen McNeill at 416-250-3695

Delivered by Facsimile Only (1-519-746-1122)

Eric-Mark Kraushaar  
Barrister and Solicitor  
620 Davenport Rd  
Unit 5  
Waterloo, Ontario N2V 2C2

Dear Sirs:

RE: 144 Park Ltd. by its Court Appointed Trustee, Collins Barrow Toronto Limited sale to Laurie Gay  
Cyrankiewicz  
Unit 4, Level 15, WSCP 591  
Suite 1504, 144 Park Street, Waterloo, Ontario N2L 0B6

We are pleased to advise that the Declaration and Description creating the condominium were registered in the Land Registry Office for the Land Titles Division of Waterloo on May 25, 2015 pursuant to Instrument Number WR882241 thereby creating Waterloo Condominium No. 591.

We also wish to advise you that Collins Barrow Toronto Limited was appointed by court order as Trustee of the property owned by 144 Park Ltd., including the units in the condominium. The court order was registered on title to said property on January 23, 2015 as Instrument No. WR863820.

At the time of execution of the Agreement of Purchase and Sale, the Vendor agreed to sell to the Purchaser(s) a second Parking Unit. Unfortunately there are not sufficient parking units available to be sold in this project. Accordingly, the Court Appointed Trustee is requesting that the Purchaser(s) agree to amend the Agreement of Purchase and Sale to delete the second Parking Unit and correspondingly reduce the Purchase Price by the amount of \$33,900.00 (inclusive of HST). If your client is agreeable to same, please sign and return a copy of this letter to us by no later than 5:00 p.m. on June 22, 2015 and we will then be in a position to set a final closing date. If we do not hear from you by that time or if your client is not agreeable to the Amendment, the Trustee may seek a Court Order terminating the Agreement of Purchase and Sale.

Yours very truly,  
Harris, Sheaffer LLP

Mark Karoly\*

Mark Karoly

\*Executed pursuant to the Electronic Commerce Act

The undersigned agrees to amend the Agreement of Purchase and Sale in the manner described above. Dated this \_\_\_\_\_ day of June, 2015.

Laurie Gay Cyrankiewicz, by his/her/their solicitor  
Eric-Mark Kraushaar.

Per \_\_\_\_\_  
Eric-Mark Kraushaar

BARRY ROTENBERG

GARY H. HARRIS

ROBERT D. SHEAFFER

PHILIP J. DRAPER

MARK F. FREEDMAN  
(1981 - 2009)

JEFFREY P. SILVER

STEPHEN M. KARR

MARTIN P. HOUSER

MARK L. KAROLY

MICHAEL J. BAUM

ARI M. KATZ

RAZVAN NICOLAE

ROBERT STORIE

This is Exhibit "I" referred to in the Affidavit of  
Ryan Cyrankiewicz sworn October 14, 2015

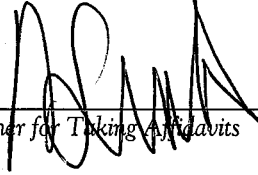

---

*Commissioner for Taking Affidavits*

**HARRIS, SHEAFFER LLP****BARRISTERS & SOLICITORS**

YONGE CORPORATE CENTRE  
4100 YONGE STREET, SUITE 610, TORONTO, ONTARIO M2P 2B3  
TELEPHONE (416) 250-5300 / FACSIMILE (416) 250-5300

July 21, 2015

**FAX COVER SHEET:**

To: Eric-Mark Kraushaar

Barrister and Solicitor

Fax: 1-519-746-1122

From:

Karen McNeill

Direct Line: 416-250-3695

Number of pages including cover sheet: 1

RE: 144 Park Ltd. s/t Laurie Gay Cyrankiewicz  
Unit 4, Level 15, Unit 2, Level 3, Unit 36, Level 1, Unit 41, Level 3, WSCP 591  
Occupancy Date: September 30, 2014  
Our File No: 090328

Please be advised that Collins Barrow Toronto Limited was appointed by court order as trustee (the "Trustee") of the property owned by 144 Park Ltd., including the units in the condominium. The court order was registered on title to the property on January 23, 2015 as Instrument No. WR863820.

The Trustee has been working with lenders and other stakeholders in this project, including certain members of the Ad Hoc Purchasers' Committee and the potential developer of 155 Uptown Waterloo, to find a meaningful parking solution to the current shortage of parking in 144 Park. In connection therewith, the Trustee has reached a potential solution that balances the many stakeholder interests. The allocation of some of the Parking Units in this project are now being reallocated in order to achieve this solution.

In this regard, your client has now been allocated a new Parking Unit and this allocation will take effect at noon on July 24, 2015. Your client's new Parking Unit allocation is Unit 36, Level 1. Please advise your client that arrangements must be made to move vehicles from the previously allocated Parking Unit at noon on July 24, 2015 because the previously allocated Parking Unit has been reallocated for someone else's use commencing at noon on July 24, 2015. Please be further advised that if your client agreed to purchase more than one Parking Unit, you must check the re line of this fax to verify which Parking Unit has been reallocated.

In the event your client requires any assistance in locating their new Parking Unit, kindly speak to the Trustee's site representative, Ms. Karla Roelofs. The Trustee is most grateful for your cooperation and assistance in effecting this allocation. The Trustee intends to schedule a Title Transfer Date as soon as possible.

Warning: The information contained in this fax is confidential, and may be subject to solicitor-client privilege. It is intended solely for the use of the party to whom it is addressed. Any distribution, copying or disclosure of this fax, other than by its intended recipient, is strictly prohibited. If you received this fax in error, please advise us immediately by telephone, and return the original transmission to us by mail without making a copy.

BARRY ROYENBERG

GARY H. HARRIS

ROBERT D. SHEAFFER

PHILIP J. DRAPER

MARK E. FREEMAN  
(1081 - 2009)

JEFFREY P. SILVER

STEPHEN M. KARR

MARTIN P. HOUSER

MARK L. KAROLY

MICHAEL J. BALM

ARI M. KATZ

RAZVAN NICOLAE

ROBERT SHORE

This is Exhibit "J" referred to in the Affidavit of  
Ryan Cyrankiewicz sworn October 14, 2015

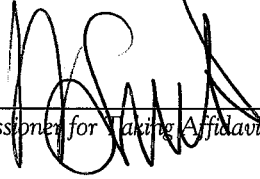

---

Commissioner for Taking Affidavits

**ERIC M. KRAUSHAAR, B.A., LL.B.**

*BARRISTER SOLICITOR NOTARY PUBLIC*

620 Davenport Road, Unit 5  
WATERLOO, Ontario  
N2V 2C2

TELEPHONE (519) 886-0088 FACSIMILE (519) 746-1122  
eric@churchill-homes.com

July 21, 2015

Harris Sheaffer LLP  
Barristers and Solicitors  
Yonge Corporate Centre  
4100 Yonge Street, Ste. 610  
Toronto, ON M2P 2B5  
Facsimile: 1-416-250-5300

Attention: Mr. Mark Karoly / Karen McNeill

Dear Sirs / Mesdames:

**Re: Cyrankiewicz purchase from 144 Park Ltd.  
Unit 4, Level 15, Unit 2, Level 3, Unit 3, Level 3, Unit 41, Level 3, WSCP 591  
Suite 1504, 144 Park Street, Waterloo, ON N2L 0B6**

We have your letter of July 21, 2015, which speaks to re-allocation of parking spaces of which our client has interim occupancy and for which our client is awaiting a conveyance. Please be advised that our client is not agreeable to changing either one or both parking spaces which it now has. We find your attempt at re-allocation is arbitrary and without legal basis. From our review, it violates the provisions of the Condominium Act, as well as section 3(k) of the January 22, 2015 Court Order of The Honourable Mr. Justice Penny appointing Collins Barrow Toronto Limited as trustee. It also impairs the value as well as the enjoyment of the unit which our client has contracted to purchase. Our client intends not to relinquish any rights in either of its parking spaces, and any interference with it by the trustee, the condominium developer or any other party, will be deemed to constitute a trespass and illegal. If you are aware of a legal basis for this attempt by the Trustee, we would appreciate if you would advise us accordingly.

Yours very truly,



**Eric M. Kraushaar**

This is Exhibit "K" referred to in the Affidavit of  
Ryan Cyrankiewicz sworn October 14, 2015

A handwritten signature in black ink, appearing to read 'Ryan Cyrankiewicz', is written over a horizontal line.

*Commissioner for Taking Affidavits*

## Eric Kraushaar

---

**From:** Karen McNeill <kmcneill@harris-sheaffer.com>  
**Sent:** July 21, 2015 3:53 PM  
**To:** Eric Kraushaar  
**Cc:** Ari Katz  
**Subject:** RE: Project: 144 Park Uptown Waterloo (Suite 1504 / Unit 4, Level 15)

**Importance:** High

We acknowledge receipt of your letter.

Pursuant to the Agreement of Purchase and Sale, the Vendor can allocate parking units at their sole discretion. The Agreement does not set out an actual allocation of a parking unit.

Accordingly, our client has instructed us to notify your client through your office of its new Parking Unit allocation as set out in our fax to your office.

Should you wish to discuss anything further, kindly contact Ari Katz directly.

Kind regards,

Karen McNeill  
Law Clerk  
[kmcneill@harris-sheaffer.com](mailto:kmcneill@harris-sheaffer.com)  
direct dial 416.250.3695

## HARRIS, SHEAFFER LLP

**BARRISTERS & SOLICITORS**

Yonge Corporate Centre  
4100 Yonge Street, Suite 610, Toronto, ON M2P 2B5  
Telephone (416) 250-5800/Facsimile (416) 250-5300  
[www.harris-sheaffer.com](http://www.harris-sheaffer.com)

---

If you wish to be removed from any future communication from Harris Sheaffer, please send a blank email to [unsubscribe@harris-sheaffer.com](mailto:unsubscribe@harris-sheaffer.com) and you will be removed from future email correspondence within 10 business days.

*One of Canada's top 5 boutique commercial real estate firms as ranked by Canadian Lawyer Magazine*

IMPORTANT NOTICE: This email communication is confidential and legally privileged. If you are not the intended recipient, please notify me at the telephone number shown above or by return email and delete this communication and any copy immediately. Thank you

---

**From:** Eric Kraushaar [<mailto:Eric@churchill-homes.com>]  
**Sent:** Tuesday, July 21, 2015 3:33 PM  
**To:** Karen McNeill  
**Subject:** RE: Project: 144 Park Uptown Waterloo (Suite 1504 / Unit 4, Level 15)

Hello Karen,  
Please see our letter attached.  
Regards  
Eric M. Kraushaar Law Office  
5-620 Davenport Road



Waterloo, Ontario  
N2V 2C2  
519-886-0088 ph  
519-746-1122 fax

This communication (and any attachments) is directed in confidence solely to the addressee(s) listed above, and may not otherwise be distributed, copied or used. The contents of this communication may also be subject to lawyer-client privilege, and all rights to that privilege are expressly claimed and not waived. If you have received this communication in error, please notify us by reply e-mail or by calling us at the above telephone number and delete this communication (and any attachments) without making a copy. Thank you.

This is Exhibit "L" referred to in the Affidavit of  
Ryan Cyrankiewicz sworn October 14, 2015

A handwritten signature in black ink, appearing to be "NSW", written over a horizontal line.

Commissioner for Taking Affidavits

**ERIC M. KRAUSHAAR, B.A., LL.B.**

*BARRISTER SOLICITOR NOTARY PUBLIC*

---

620 Davenport Road, Unit 5  
WATERLOO, Ontario  
N2V 2C2

*TELEPHONE* (519) 886-0088      *FACSIMILE* (519) 746-1122  
eric@churchill-homes.com

July 23, 2015

Harris Sheaffer LLP  
Barristers and Solicitors  
Yonge Corporate Centre  
4100 Yonge Street, Ste. 610  
Toronto, ON M2P 2B5  
Facsimile: 1-416-250-5300

Attention: Mr. Ari Katz / Karen McNeill

Dear Sirs / Mesdames:

**Re: Cyrankiewicz purchase from 144 Park Ltd.  
Unit 4, Level 15, Unit 2, Level 3, Unit 3, Unit 41, Level 3, WSCP 591  
Suite 1504, 144 Park Street, Waterloo, ON N2L 0B6**

---

We are responding to the email from Ms. Karen McNeill, in reply to our letter of July 21, 2015. Our client maintains the same position as set out in our letter to you of July 21, 2015. The discretion of the Vendor to allocate parking units as per the agreement of purchase and sale has been exercised by the Vendor. At the time of our client taking Interim Occupancy, the parking spaces allocated by the Vendor to the Purchaser were identified in the document entitled "144 Park - Key Release" dated October 8, 2014 and signed by the Vendor's representative. A copy is attached for your reference. It is our position that upon exercising that discretion, the Vendor's right to do so is exhausted and there is no further or on-going discretionary right to re-allocate parking spaces. In the agreement of purchase and sale, clause C.3 of Schedule C speaks to the purchaser's right to retain occupancy of the Unit (which by definition includes the parking spaces) during Interim Occupancy. Clause C.4 relates the taking of Interim Occupancy as being of significance equal to closing of the transaction. It is our position that upon taking Interim Occupancy, our client is vested with the equitable right and the legal right, pursuant to the Condominium Act and the Order appointing the Trustee, to have the Vendor/Trustee provide a conveyance of that Unit. At that stage, there is no right or opportunity for the Vendor to alter or re-allocate what constitutes the Unit. We have previously referenced the Condominium Act and the Court Order which in our view support this position.

Our client will not relinquish possession or its rights in the parking spaces of which it has Interim Occupancy. The Vendor or the Trustee has no legal basis to interfere with that possession and occupancy, by way of self-help or other means, without a court order authorizing it to do so.

Accordingly, in the event that the Vendor or Trustee wishes to pursue the matter further, we require that it be pursued by court application. Our client is prepared to abide by a resulting court order. Otherwise, our client stands by its position that any interference with its possession and Interim Occupancy is not lawful and that it constitutes a trespass.

Yours very truly,

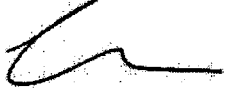
A handwritten signature in black ink, appearing to read 'Eric M. Kraushaar', written over a horizontal line.

**Eric M. Kraushaar**

Encl.

Suite: 1504  
Homeowner Name(s): Laurie & Ryan Cyrankiewicz  
Date: Oct. 8, 2014  
Parking (if applicable): 3-2 & 3-3  
Locker (if applicable): 3-41

CS1-2555

I/we do hereby acknowledge receipt of the following:

<input checked="" type="checkbox"/> Suite entry keys	<input checked="" type="checkbox"/> Keyless entry fobs
<input checked="" type="checkbox"/> Common element Keys	<input checked="" type="checkbox"/> Homeowner's manual
<input checked="" type="checkbox"/> Garage door remotes	<input checked="" type="checkbox"/> Welcoming gift

\_\_\_\_\_  
Signature

\_\_\_\_\_  
Signature

In regards to suite access, please choose one of the following two options:

I/we hereby authorize 144 Park Uptown Waterloo and associated sub-contractors to enter my premises. It is understood that all sub-contractor work will be supervised and that notification of the entry will be left in my suite.

\_\_\_\_\_  
Signature

\_\_\_\_\_  
Signature

OR

I/we do NOT authorize 144 Park Uptown Waterloo and associated sub-contractors to enter my premises without an appointment. It is understood that it will take longer to resolve my warrantable deficiencies and that I will have to be home to supervise all work performed in my suite.

\_\_\_\_\_  
Signature

\_\_\_\_\_  
Signature

\_\_\_\_\_  
Mady Developments Representative's Signature

This is Exhibit "M" referred to in the Affidavit of  
Ryan Cyrankiewicz sworn October 14, 2015

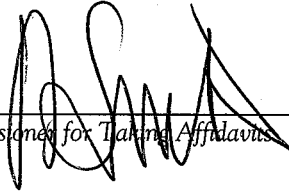
A handwritten signature in black ink, consisting of several loops and a final sharp stroke, positioned above a horizontal line.

---

*Commissioner for Taking Affidavits*

---

**From:** Ari Katz [mailto:akatz@harris-sheaffer.com]

**Sent:** July 23, 2015 2:25 PM

**To:** Eric Kraushaar

**Cc:** Karen McNeill

**Subject:** RE: Project: 144 Park Uptown Waterloo (Suite 1504 / Unit 4, Level 15)

Hi Eric,

It is my client's position that it is legally entitled pursuant to the terms of the Agreement of Purchase and Sale to allocate and re-allocate parking units at its discretion. In the event your clients fail to move vehicle(s) to the re-allocated spaces, my client will have no choice but to consider towing your clients' vehicles due to trespass on Parking Units owned by the developer. My client is proceeding to implement a solution in the best interests of all stakeholders of this project and will not allow individual purchasers to interfere with its court appointed mandate. Your client is certainly entitled to attend court to seek an order altering this process, but in the interim my client wishes to caution your client against any action or omission that would interfere with the re-allocation process intended to rectify an already unfair situation.

Regards,

Ari

---

Ari M. Katz, B.Sc. (Hons), LL.B.

HARRIS, SHEAFFER LLP

4100 Yonge Street, Suite 610 | Toronto, ON M2P 2B5

Tel: 416.250.2869 | Fax: 416.250.5300 | e-mail: [akatz@harris-sheaffer.com](mailto:akatz@harris-sheaffer.com)

*One of Canada's top 5 boutique commercial real estate firms as ranked by Canadian Lawyer Magazine*

<https://ca.linkedin.com/in/arimkatz>

This is Exhibit "N" referred to in the Affidavit of  
Ryan Cyrankiewicz sworn October 14, 2015

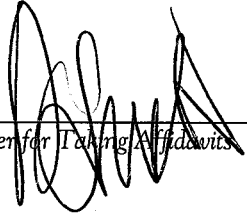
A handwritten signature in black ink, consisting of several loops and a final sharp stroke, positioned above a horizontal line.

---

*Commissioner for Taking Affidavits*



**From:** Karen McNeill [mailto:kmcneill@harris-sheaffer.com]

**Sent:** August 6, 2015 12:29 PM

**To:** Eric Kraushaar

**Cc:** Ari Katz

**Subject:** Project: 144 Park Uptown Waterloo/File #: 090328/Purchasers: Michael Herbert Robinson Williams/Suite: 903

**RE: Urgent notice of postponement of final closing \*\*PLEASE ADVISE YOUR CLIENT AND YOUR CLIENT'S LENDER\*\***

As you know, Collins Barrow Toronto Limited was appointed by court order as trustee (the "Trustee") of the property owned by 144 Park Ltd., including the units in the condominium. The court order was registered on title to the property on January 23, 2015 as Instrument No. WR863820.

Please be advised that the Trustee has received numerous requests for information relating to the reallocation of some of the Parking Units in this project in order to achieve the parking solution to the current shortage of parking in 144 Park. In this regard, the Trustee will be bringing a motion on August 18, 2015 seeking Court direction and approval in respect of parking issues at 144 Park. **Therefore, please be advised that the Title Transfer Date will be postponed until such time as the Trustee and other stakeholders have opportunity, if desired, to voice any concerns at the motion hearing.**

At this time, your client should continue to park vehicles in the parking units as re-allocated. We will advise you of re-scheduled Title Transfer Date once above noted motion hearing is concluded.

Karen McNeill

Law Clerk

[kmcneill@harris-sheaffer.com](mailto:kmcneill@harris-sheaffer.com)

direct dial 416.250.3695

**HARRIS, SHEAFFER LLP**  
**BARRISTERS & SOLICITORS**

Yonge Corporate Centre

4100 Yonge Street, Suite 610, Toronto, ON M2P 2B5

Telephone (416) 250-5800/Facsimile (416) 250-5300

[www.harris-sheaffer.com](http://www.harris-sheaffer.com)

If you wish to be removed from any future communication from Harris Sheaffer, please send a blank email to [unsubscribe@harris-sheaffer.com](mailto:unsubscribe@harris-sheaffer.com) and you will be removed from future email correspondence within 10 business days.

*One of Canada's top 5 boutique commercial real estate firms as ranked by Canadian Lawyer Magazine*

IMPORTANT NOTICE: This email communication is confidential and legally privileged. If you are not the intended recipient, please notify me at the telephone number shown above or by return email and delete this communication and any copy immediately. Thank you

This is Exhibit "O" referred to in the Affidavit of  
Ryan Cyrankiewicz sworn October 14, 2015

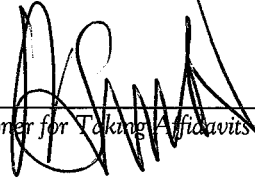

---

Commissioner for Taking Affidavits

-----Original Message-----

From: Sam P. Rappos [<mailto:samr@chaitons.com>]

Sent: August 27, 2015 3:47 PM

To: Eric Kraushaar

Cc: akatz@harris-sheaffer.com; 'Arif N. Dhanani'; Harvey G. Chaiton; Bryan A. Tannenbaum

Subject: RE: 144 Park Ltd., Court File No. CV15-10843-00CL - Parking Matters

Eric,

The October 5 motion will be a motion for advice and directions by the Trustee. We expect that Trustee will be seeking authority to reallocate spots and, if necessary, to terminate agreements of purchase and sale with purchasers that have two parking spots. Given your comments below, your client will be impacted by the relief being sought at the October 5 motion.

Regards,  
Sam

Sam P. Rappos  
Lawyer | Chaitons LLP | T: 416.218.1137

IN THE MATTER OF THE CONSTRUCTION LIEN ACT, R.S.O. 1990, c. C.30, AS AMENDED

AND IN THE MATTER OF AN APPLICATION MADE BY 144 PARK LTD. FOR THE APPOINTMENT OF A TRUSTEE  
UNDER SECTION 68(1) OF THE CONSTRUCTION LIEN ACT, R.S.O. 1990, c. C.30, AS AMENDED

Court File No. CV15-10843-00CL

**ONTARIO**  
**SUPERIOR COURT OF JUSTICE**  
**PROCEEDING COMMENCED AT**  
**TORONTO**

**AFFIDAVIT**

**DUNCAN, LINTON LLP**  
Barristers & Solicitors  
P.O. Box 457  
45 Erb Street East  
Waterloo, Ontario  
N2J 4B5

Irwin A. Duncan (LSUC #12857G)  
e: [iad@kwlaw.net](mailto:iad@kwlaw.net)

t: (519) 886-3340  
f: (519) 886-8651

Lawyers for Richard Magnussen, Marilyn Magnussen,  
Joseph Siefried, Susan Siefried, AJ Mueller, Kerry Mueller,  
Ryan Cyrankiewicz and Laurie Cyrankiewicz

IN THE MATTER OF THE CONSTRUCTION LIEN ACT, R.S.O. 1990, c. C.30, AS AMENDED

AND IN THE MATTER OF AN APPLICATION MADE BY 144 PARK LTD. FOR THE APPOINTMENT OF A TRUSTEE  
UNDER SECTION 68(1) OF THE CONSTRUCTION LIEN ACT, R.S.O. 1990, c. C.30, AS AMENDED

Court File No. CV15-10843-00CL

**ONTARIO  
SUPERIOR COURT OF JUSTICE  
(COMMERCIAL LIST)**

PROCEEDING COMMENCED AT TORONTO

**RESPONDING RECORD**

Re: Parking Matters  
Originally Returnable: October 5, 2015  
Adjourned To: October 16, 2015

**DUNCAN, LINTON LLP**  
Barristers & Solicitors  
P.O. Box 457  
45 Erb Street East  
Waterloo, Ontario  
N2J 4B5

Irwin A. Duncan (LSUC #12857G)  
e: [iad@kwlaw.net](mailto:iad@kwlaw.net)  
t: (519) 886-3340  
f: (519) 886-8651

Lawyers for Richard Magnussen, Marilyn Magnussen,  
Joseph Siefried, Susan Siefried, AJ Mueller, Kerry Mueller,  
Ryan Cyrankiewicz and Laurie Cyrankiewicz